

PORSCHE

Technical Manual

Boxster

Technical Information

Repair

Contents:

Group 0

Entire vehicle – General

Foreword

The workshop documentation for the Boxster model has the designation "**Boxster**" **Technical Manual** and contains **Technical Information** as well as instructions on **Repairs**.

The integration of the technical information published in the "Boxster" Technical Manual with the descriptive matter on repairs provides the user with a complex reference work that combines into one book associated or cross-referenced material of relevance to workshops and originating from various information media.

The "Boxster" Technical Manual consists of 15 folders, subdivided into the following Groups

0	Entire vehicle – General
0	Diagnosis, part 1 (up to Repair Group 45) * ¹
0	Diagnosis, part 2 (as of Repair Group 69) * ²
1	Engine, part 1 (up to Repair Group 13) * ³
1	Engine, part 2 (as of Repair Group 15) * ⁴
2	Fuel, exhaust, engine electronics
3	Transmission, manual transmission
3	Transmission, automatic transmission
4	Running gear
5	Body
6	Body equipment, exterior
7	Body equipment, interior
8 / 9	Air conditioning / Electrics
9	Circuit diagrams, part 1 (up to and including the '99 model) * ⁵
9	Circuit diagrams, part 2 (as of the '00 model) * ⁶

*¹ The two folders with Group 0 are to be regarded as one folder; i.e. file the "Technical Information" notices only in front of the repair descriptions in the folder "Group 0 – Diagnosis, part 1" (**up to Repair Group 45**).

| *² The **second folder** "Group 0 – Diagnosis, part 2" (**as of Repair Group 69**) includes the further Repair Groups belonging to Group 0.

| *³ The two folders with Group 1 are to be regarded as one folder; i.e. file the "Technical Information" notices only in front of the repair descriptions in the folder "Group 1 – Engine, part 1" (**up to Repair Group 13**).

| *⁴ The **second folder** "Group 1 – Engine, part 2" (**as of Repair Group 15**) includes the further Repair Groups belonging to Group 1.

- *5 The two folders with Group 9 are to be regarded as one folder; i.e. file the "Technical Information" notices only in front of the repair descriptions in the folder "Group 9 – Circuit diagrams, part 1" (**up to the '99 model**).
- *6 The **second folder** "Group 9 – Circuit diagrams, part 2" (**as of the '00 model**) includes the further circuit diagrams belonging to Group 9.

The "Boxster" Technical Manual has the same structure in each folder, with the following breakdown for all Groups:

Title page, "Boxster" Technical Manual

> Foreword

Title page: "Technical Information"

> Table of Contents, Technical information
> Technical information

Title page: "Repair"

> Repair Groups: overview
> Table of Contents, repairs
> General / technical data
> Instructions on repairs

As can be seen from the breakdown, the published Technical Information is in the front part of each folder – numbered according to the Groups. The Table of Contents assigned to each Group will be periodically updated.

Following the Technical Information, separated by a title page, the instructions on repairs – assigned according to the Groups or broken down into Repair Groups – are included in the folder.

The instructions on repairs will be extended and updated by means of supplements.

Note

Sheets that already exist in the "Boxster" Technical Manual and are updated or revised and thereby exchanged by a supplement are designated "Replacement sheet". Revisions or technical modifications on pages of these replacement sheets are identified for the user with a vertical bar at the margin.

Record sheet for supplements to

Technical Manual *Boxster*

We ask that you file the supplement under the appropriate Repair Groups and enter them in the table below to provide an overview.

Supplement No.	Date filed	Signature
1	already filed	---
2		---
3		---
4		---
5		---
6		---
7		---
8		---
9		---
10		---
11		---
12		---
13		---
14		---
15		---
16		---
17		
18		
19		
20		

Record sheet for supplements to

"Boxster" Technical Manual

We ask that you file the supplement under the appropriate Repair Groups and enter them in the table below to provide an overview.

Supplement No.	Date filed	Signature
21		
22		
23		
24		
25		
26		
27		
28		
29		
30		
31		
32		
33		
34		
35		
36		
37		
38		
39		
40		

Boxster Technical Manual – Repair

General

The Technical Manual – Repair – describes all essential work operations requiring special instructions to ensure that repairs are performed properly. It should be in the hands of the workshop foremen and the workshop personnel, as careful compliance with the stated instructions is a precondition for maintaining the traffic and operating safety of the vehicle. In addition, of course, the generally customary basic safety rules for the repair of motor vehicles are unrestrictedly applicable.

Structure

Overview of Repair Groups

Contents

Technical data / general

Description of repairs

Breakdown of Repair Groups

Tools, special tools and materials required for repair

Exploded drawing and illustration of sequence

Legend for exploded drawing and description of sequence

Instructions for assembly and adjustment

The Technical Manual is regularly expanded by supplements, which must be incorporated immediately to preserve the usefulness of the Manual. As verification of completeness, the record sheet should be completed.

Structure of exploded view

A 17 B Engine - Lubrication C Boxster

H Removing and installing oil pump with coolant guide housing

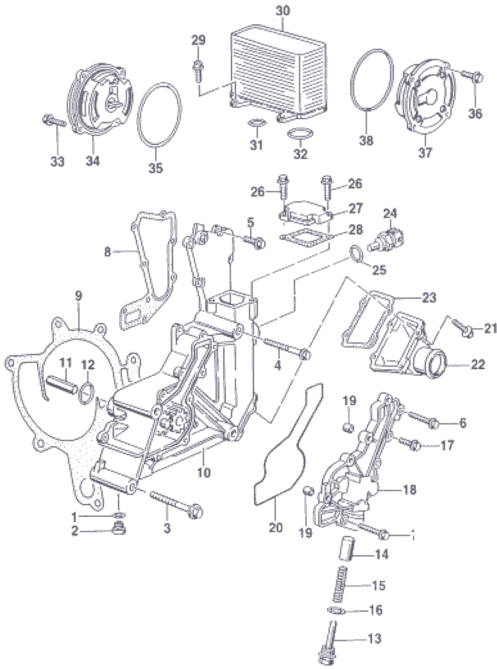

D 17 - 6 F 17 20 19 Removing and installing oil pump with coolant guide housing
E 986171 G Printed in Germany, 1996

C Boxster B Engine - Lubrication A 17

H Removing and installing oil pump with coolant guide housing

J	No.	Designation	Qty.	Removal	K Note:	Installation
	1	Coolant drain plug M10 x 1				Tightening torque: 10 + 5 Nm (7 + 3.5 ftb.)
	2	Sealing ring A10 x 13.5				Always replace
	3	Hexagon-head bolt M10 x 100				Tightening torque: 45 Nm (33 ftb.)
	4	Hexagon-head bolt M10 x 100	1			Tightening torque: 45 Nm (33 ftb.)
	5	Hexagon-head bolt M6 x 20	8			Tightening torque: 10 Nm (7 ftb.)
	6	Hexagon-head bolt M6 x 70				
	7	Hexagon-head bolt M6 x 70				
	8	Gasket				Always replace; insert or fit only if coolant guide housing has been put onto crankcase
	9	Gasket				Always replace; insert or fit only if coolant guide housing has been put onto crankcase
	10	Oil pump with coolant guide housing				
	11	Driver				Always replace
	12	O-ring				
	13	Plug with guide pin				Tightening torque: 25 Nm (18 ftb.)

17 20 19 Removing and installing oil pump with coolant guide housing
G 986171 E F 17 - 7 D
Printed in Germany, 1996

- A = Repair Group, numbers
- B = Repair Group, text
- C = Vehicle type
- D = Page number
- E = Internal Porsche number
- F = Work operation, consisting of "After-sales service number" and "Title"

- G = Imprint, supplement number, year of printing
- H = Title of exploded view
- J = Item number of exploded view, in disassembly sequence
- K = Special instructions to be followed during installation or removal

Structure of sequence description

A 57 **B** Door front, central locking system **C** Boxster

H Removing and installing door

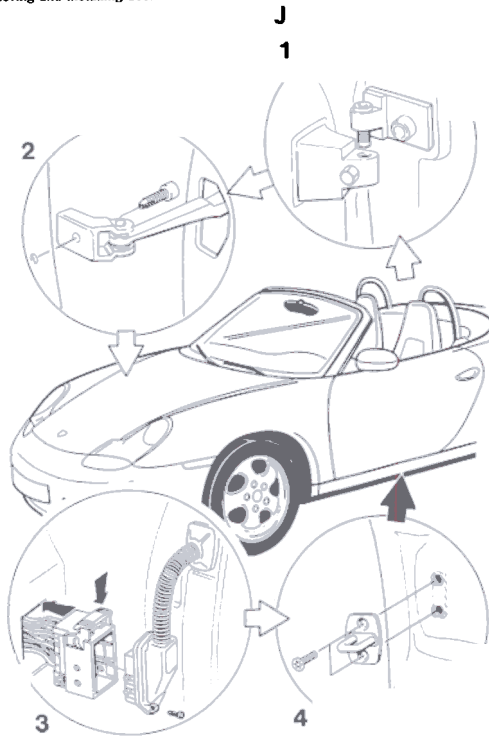

D 57 - 2

E 986571

F 57 51 37 Removing and installing door
Printed in Germany, 1996

G

C Boxster **B** Door front, central locking system **A** 57

H Removing and installing door

Removing door

J **K**
No. Procedure

L Instructions

Loosen fastening screws.

Unscrew fastening screw from door hinge.

Loosen door brake.

Unscrew hexagon socket head bolt screw on the door brake.

3 Disconnect plug connection.

Loosen hexagonal screw. Withdraw plug connection downwards and disconnect.

Loosen latch striker.

Pull door upwards out of the hinges.

Install door

No. Procedure

Instructions

Hang door.

Hang door in door hinge from above and tighten fastening screw.

2 Assemble door brake.

Screw door brake to body with hexagon socket head bolt.

Connect.

Connect plug connection, insert from below and secure with hexagon-head bolt.

4 Assemble latch striker.

Screw latch striker to the B-pillar. Adjust latch striker so that the door contour corresponds with the rear side panel.

57 51 37 Removing and installing door
Printed in Germany, 1996

G

F

E

57 - 3 **D**

A = Repair Group, numbers
B = Repair Group, text
C = Vehicle type
D = Page number
E = Internal Porsche number
F = Work operation, consisting of "After-sales service number" and "Title"

G = Imprint, supplement number, year of printing
H = Title of sequence description
J = Sequence number in order of sequence
K = Procedure in the sequence
L = Description or explanation of the procedure

Group 0:	Entire vehicle – General	0
	Maintenance	03
Group 0:	Diagnosis	0
	Sales check	01
	On-board diagnosis	03
	DME diagnosis	24
	Tiptronic diagnosis	37
	ABS diagnosis	45
Group 0:	Diagnosis	0
	Airbag diagnosis	69
	Seat memory diagnosis	72
	Heating diagnosis	80
	Alarm system diagnosis	90
	PCM diagnosis	91
	ParkAssistent diagnosis	91
	HBA diagnosis	94
Group 1:	Engine	1
	Engine – Crankcase, suspension	10
	Engine – Crankshaft, pistons	13
Group 1:	Engine	1
	Engine – Cylinder head, valve drive	15
	Engine – Lubrication	17
	Engine – Cooling	19
Group 2:	Fuel, exhaust, engine electronics	2
	Fuel supply, control	20
	Exhaust system, turbocharging	21
	Fuel system, electronic injection	24
	Fuel system, K-Jetronic	25
	Exhaust system	26
	Starter, power supply, cruise control	27
	Ignition system	28
Group 3:	Transmission, manual transmission	3
	Clutch, control	30
	Manual transmission – Actuation, housing	34
	Manual transmission – Gears, shafts, int. gearsh.	35
	Final drive, differential, differential lock	39
Group 3:	Transmission, automatic transmission	3
	Torque converter	32
	Automatic transmission – Actuation, housing	37
	Automatic transmission – Gears, control	38
	Final drive, differential, differential lock	39

Group 4:	Running gear	4
	Front wheel suspension, drive shafts	40
	Rear wheel suspension, drive shafts	42
	Wheels, tires, suspension alignment	44
	Anti-Lock Brake System (ABS)	45
	Brakes – Brake mechanics	46
	Brakes – Hydraulics, regulator, booster	47
	Steering	48
Group 5:	Body	5
	Body front	50
	Body center, roof, frame	51
	Body rear	53
	Lids, flaps	55
	Door front, central locking system	57
Group 6:	Body equipment, exterior	6
	Sliding roof	60
	Convertible top, hardtop	61
	Bumpers	63
	Glazing, window control	64
	Exterior equipment	66
	Interior equipment	68
	Passenger protection	69
Group 7:	Body equipment, interior	7
	Linings, insulation	70
	Seat frames	72
	Seat upholsteries, covers	74
Group 8:	Air conditioning	8
	Heating	80
	Ventilation	85
	Air conditioning	87
	Auxiliary air conditioning system	88
Group 9:	Electrics	9
	Instruments, alarm system	90
	Radio, telephone, on-board computer, navigation	91
	Windshield wiper and washer system	92
	Lights, lamps, switches exterior	94
	Lights, lamps, switches interior, theft protection	96
Group 9:	Circuit diagrams	9
	Wiring (up to and including the '99 model)	97
Group 9:	Circuit diagrams	9
	Wiring (from the '00 model)	97

0	Entire vehicle – General	
0	General	
	Engine	0 - 1
	Transmission	0 - 3
	Running gear	0 - 5
	Body	0 - 15
	Electrics	0 - 25
	Technical data	0 - 31
	Plug-in couplings for pipelines (new system)	0 - 41
	Lifting the vehicle	0 - 47
	Power supply – general (work instructions after disconnecting the battery)	0 - 49
	Technical data Boxster (2.7 l)	0 - 53
	Technical data Boxster S (3.2 l)	0 - 65
01	Sales check	
	Removing transport arrangement	01 - 1
	Convertible top: Checking operation	01 - 3
	Coding alarm system for Great Britain and Belgium	01 - 5
03	Maintenance	
	Maintenance schedule	1
03 20 00	Maintenance	03 - 1

0 Power unit - general

Engine M 96/20

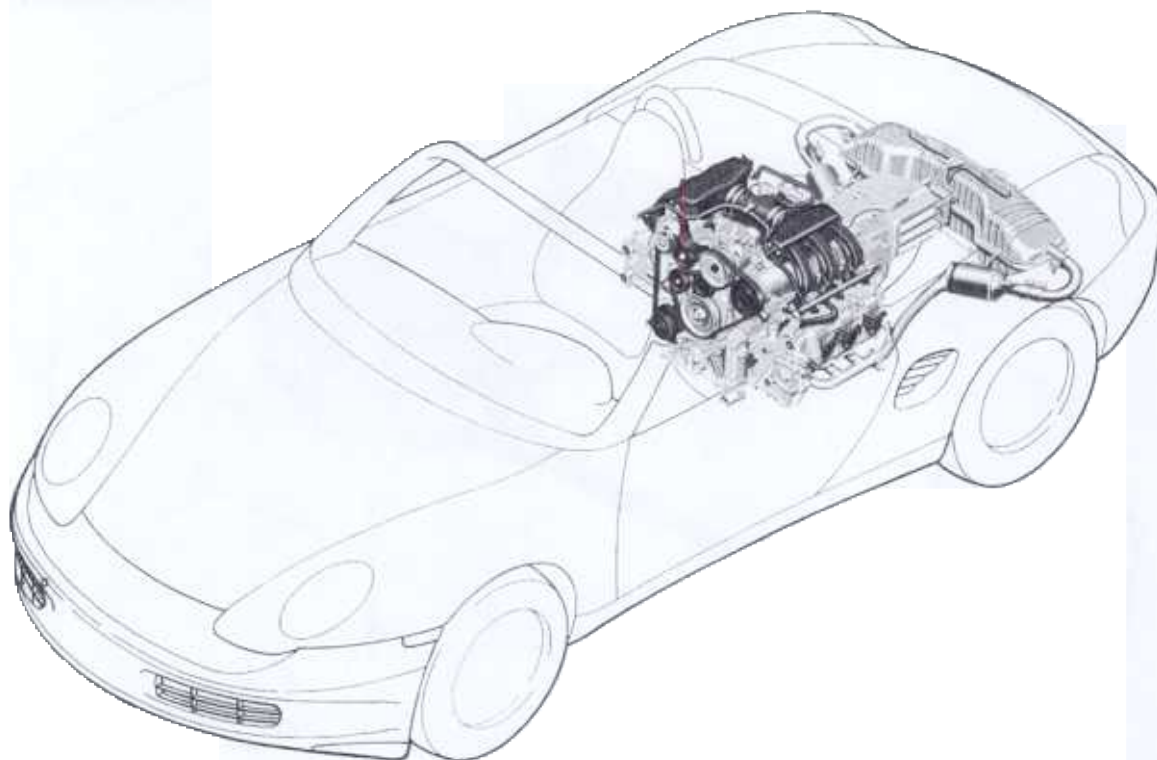

638 - 96

Type	6-cylinder aluminium opposed-cylinder engine, water-cooled	
Bore / stroke	mm	85.5 / 72
Displacement (actual)	cm ³	2480
Compression ratio		11.0 : 1
Max. engine power	kW/HP	150 / 204
at engine speed	rpm	6000
Max. torque	Nm (ftlb.)	245 (181)
at engine speed	rpm	4500
Engine control	Bosch M5.2 with static high-voltage distribution, sequential injection, cylinder-specific knock control, stereo oxygen-sensor control and diagnostic system.	
Cylinder head	2 overhead camshafts with hydraulic valve clearance compensation	
Camshaft drive	Porsche VarioCam	
Type of fuel	RON 98 premium unleaded	

Engine-cooling diagram

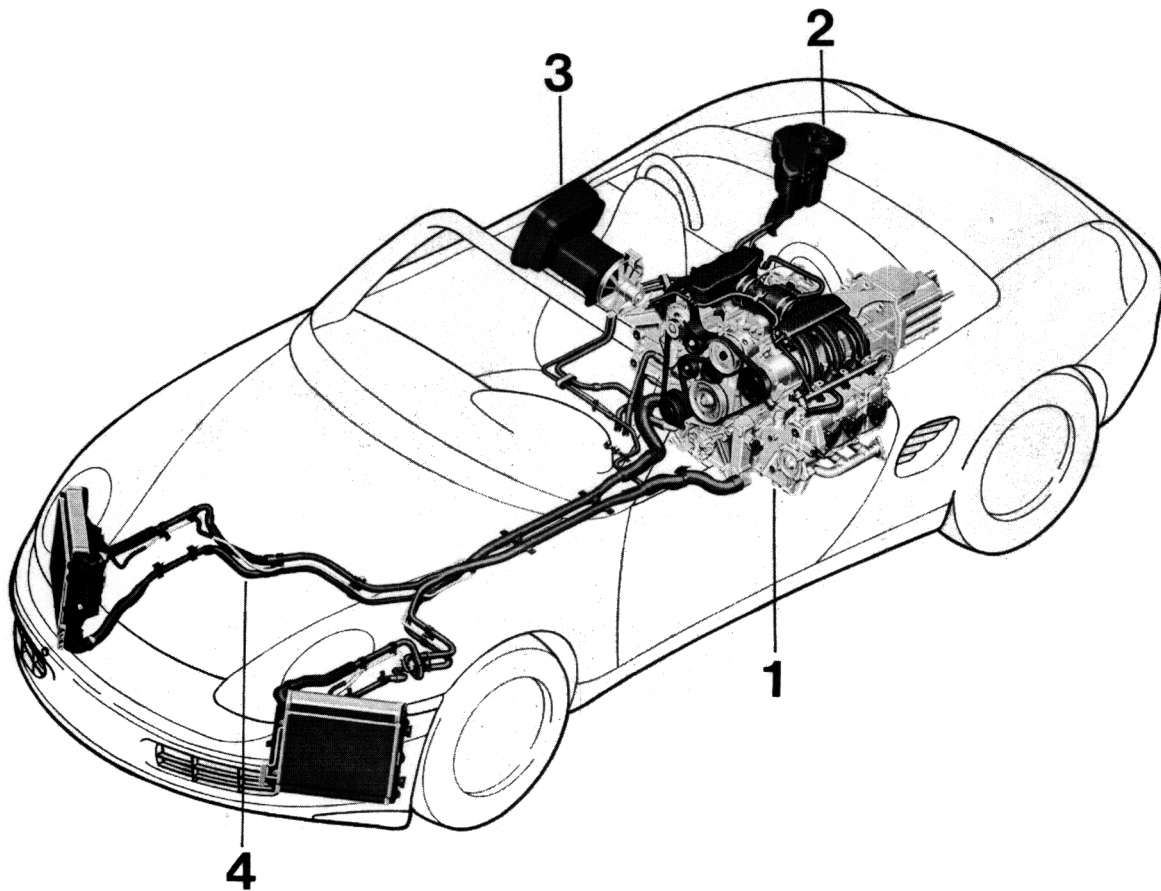

- 1 - Opposed-cylinder engine, water-cooled
- 2 - Expansion tank
- 3 - Fan for engine-compartment cooling
- 4 - Water circuit

0 Transmission - general

Manual transmission (G 86)

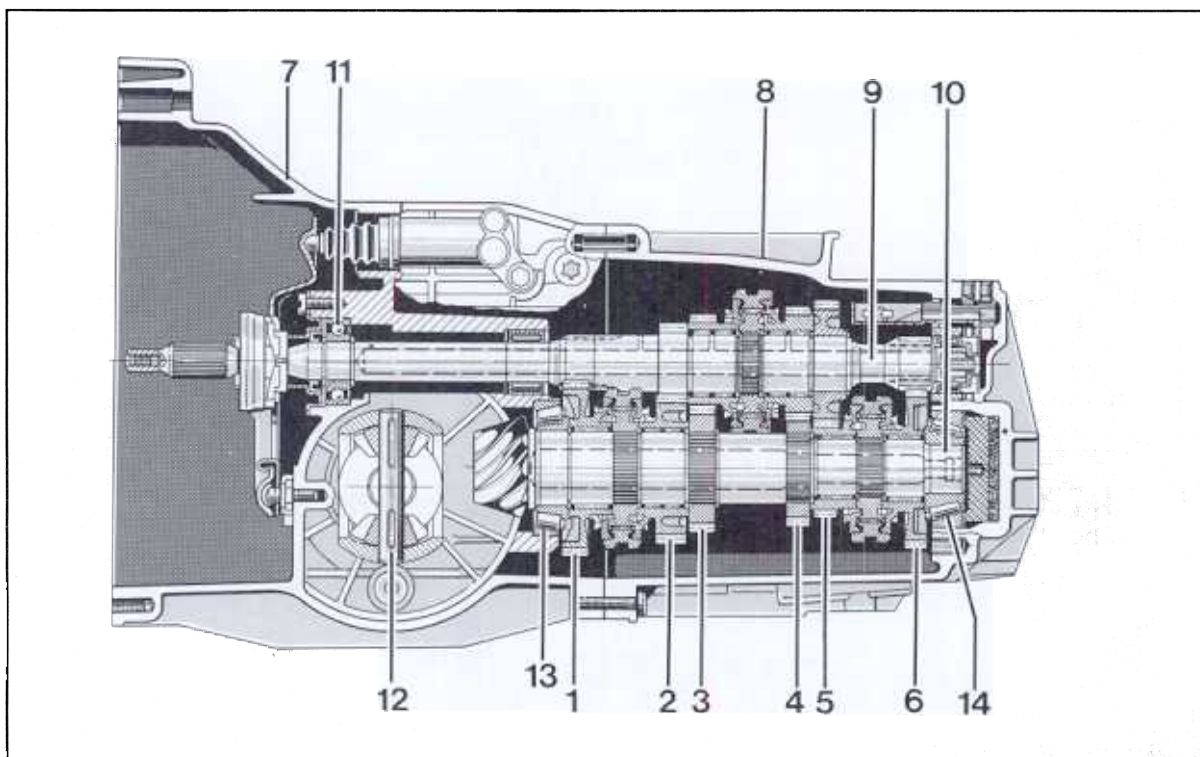

1 - 1st gear

2 - 2nd gear

3 - 3rd gear

4 - 4th gear

5 - 5th gear

6 - Reverse gear

7 - Transmission housing

8 - Transmission case cover

9 - Input shaft

10 - Output shaft

11 - Ball bearing

12 - Differential

13 - Tapered roller bearing

14 - Tapered roller bearing

Tiptronic transmission (A86)

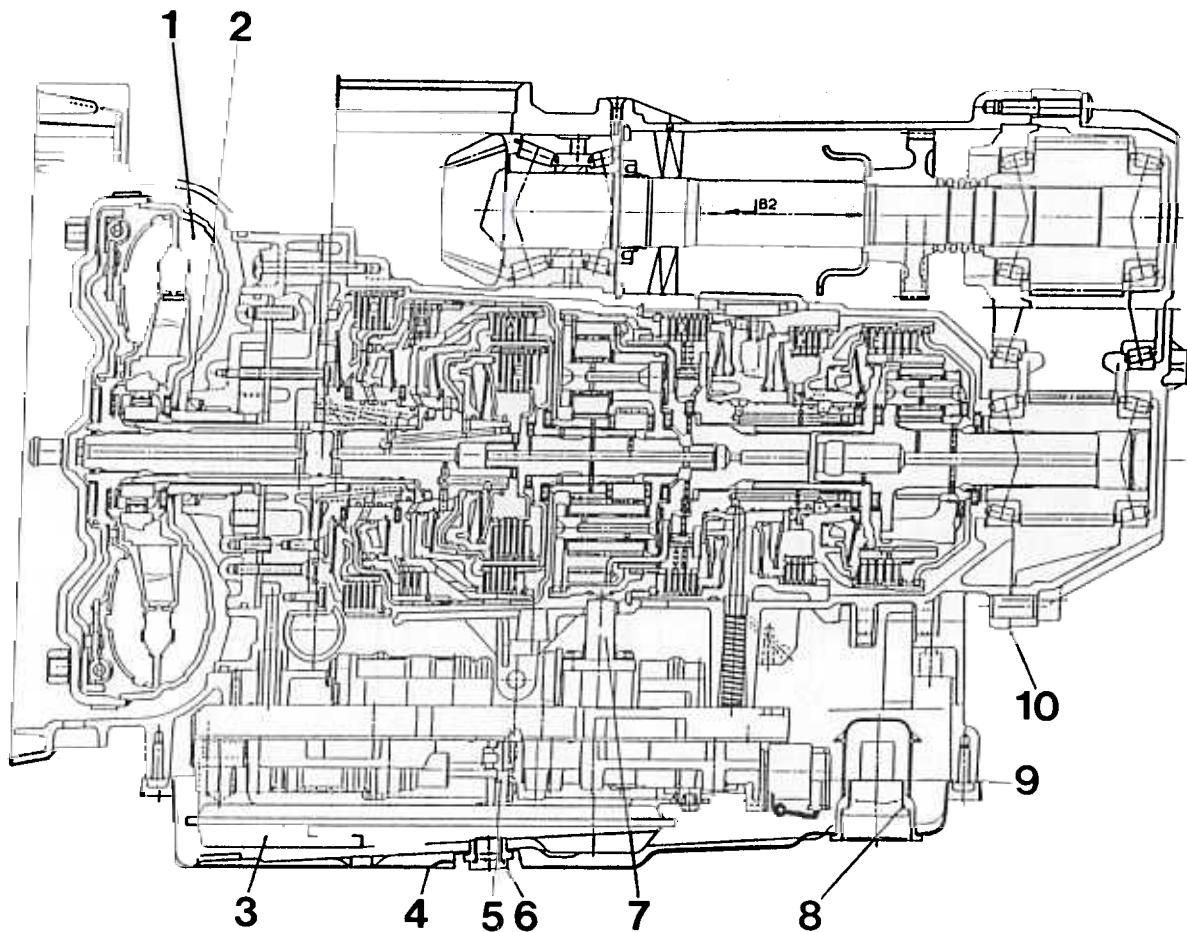

283 - 96

- 1 - Torque converter
- 2 - Sealing ring for torque converter
- 3 - ATF filter
- 4 - ATF pan
- 5 - Hydraulic control unit

- 6 - ATF drain plug
- 7 - Transmission input speed sensor
- 8 - ATF filler screw
- 9 - Gasket for ATF pan
- 10 - Gasket for spur gear

0 Running gear - general

Running gear - overview

Front axle / steering

McPherson wheel suspension with offset spring. Twin-tube gas pressure shock absorbers in standard or sports model.

In order to obtain greater stiffness with reduced intrinsic weight as compared with steel, the following components have been made from aluminium:

Control arms, diagonal brace, track rod, wheel carriers and cross members / side member.

Rack-and-pinion steering gear ($i = 16.9 : 1$) with hydraulic assistance.

Steering wheel longitudinally adjustable (40 mm).

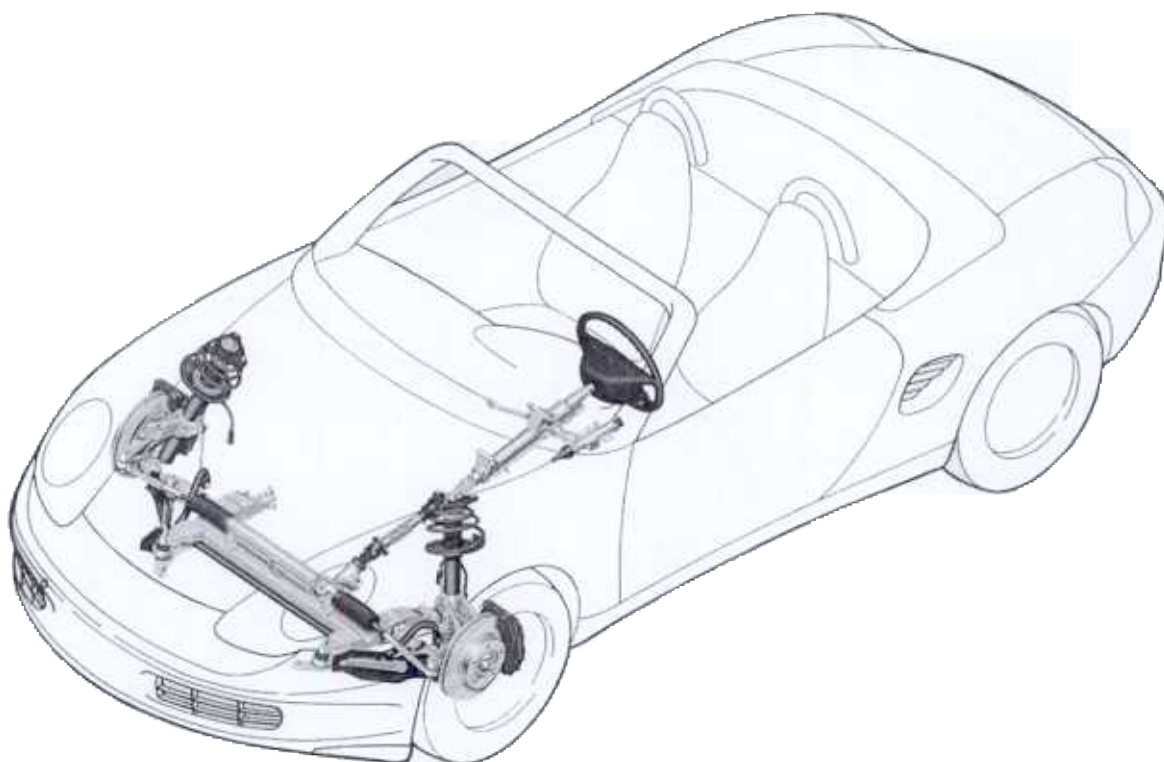

Rear axle

McPherson wheel suspension with offset spring.

Twin-tube gas-filled shock absorbers in standard or sports model.

In order to obtain greater stiffness with reduced intrinsic weight as compared with steel, the following components have been made from aluminium:

Control arms, diagonal brace, track rod, wheel carriers and side members.

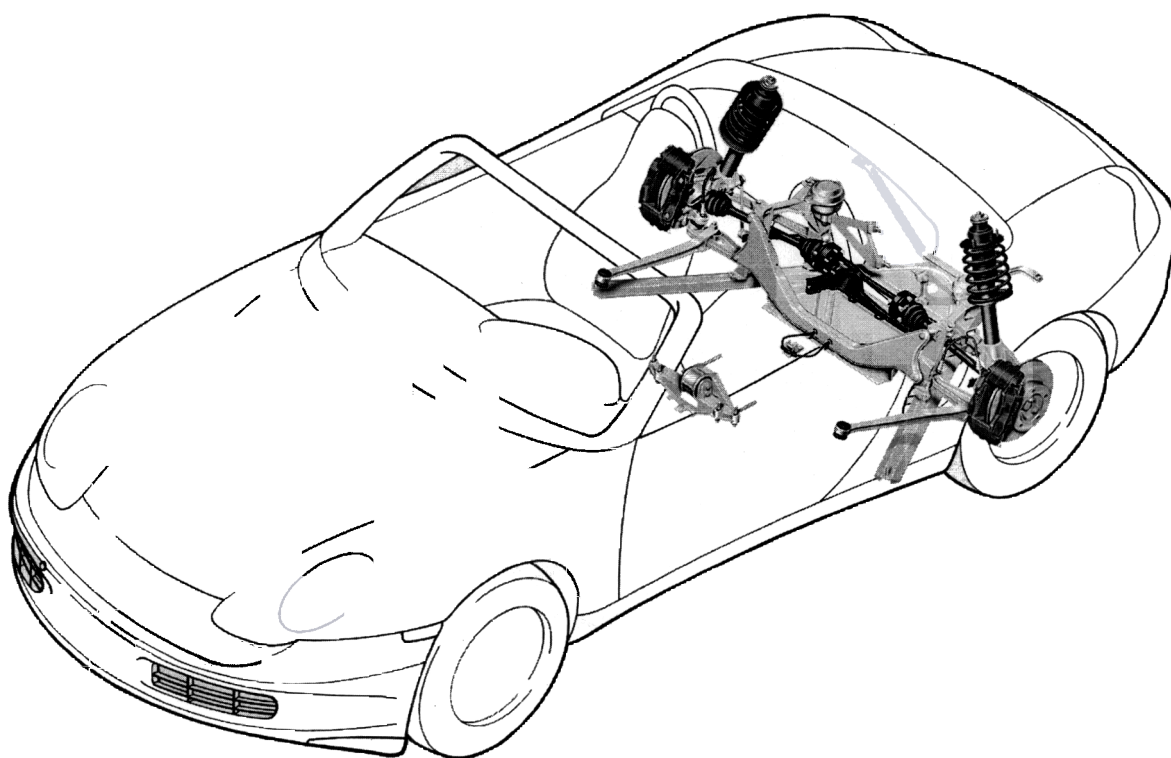

383-96

Wheels and tyres

	Front	Rear
Standard		
Wheels:	6J X 16	7J X 16
Tyres:	205/55 R 16	225/50 R 16

On special request

Wheels:	7J X 17	8.5J X 17
Tyres:	205/50 R 17	255/40 R 17

Brakes

Hydraulic dual-circuit brake system with front-axle / rear-axle brake-circuit distribution. Vacuum brake booster, internally ventilated brake disks with four-piston fixed caliper at front and rear axles.

ABS 5.3 (3-channel system) standard.
ABS/TC 5.3 (4-channel system) on special request.

TC = Traction Control, consisting of ASR (anti-slip control) and ABD (Automatic Brake Differential).

Parking brake (handbrake):
Drum brake acting mechanically on both rear wheels.

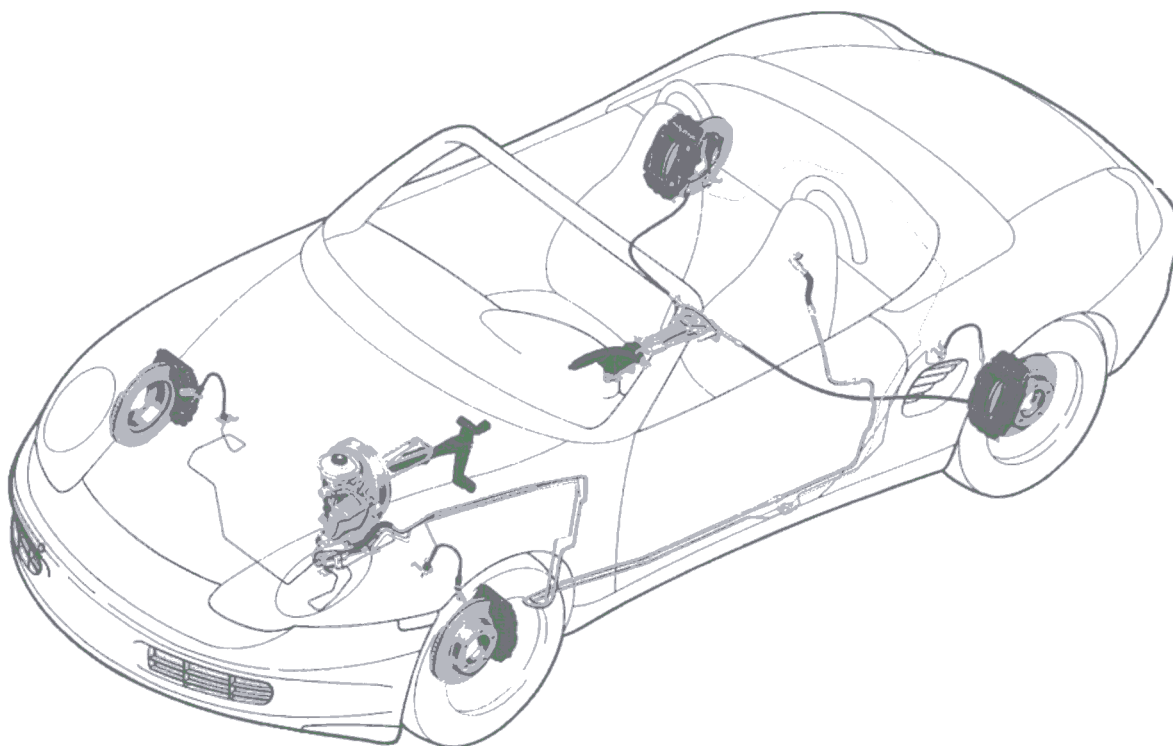

Information on ABS 5.3 and ABS/TC 5.3

General

The Porsche Boxster is equipped as **standard** with an anti-lock braking system (ABS 5.3). "Traction Control (TC)" is available on **special request** on the basis of ABS 5.3. **Traction Control (TC)** is a combination of anti-slip control (ASR) and Automatic Brake Differential (ABD). **TC is a further system for increasing driving safety.**

Compared with the ABS 5 (ABS 5 in the 993), **ABS 5.3** has been optimized with regard to installed volume and weight. Control unit (No. 1), hydraulic unit (No. 7), pump-motor relay and valve relay (No. 2) of ABS 5.3 and ABS/TC 5.3 **form a unit** that is located next to the brake master cylinder.

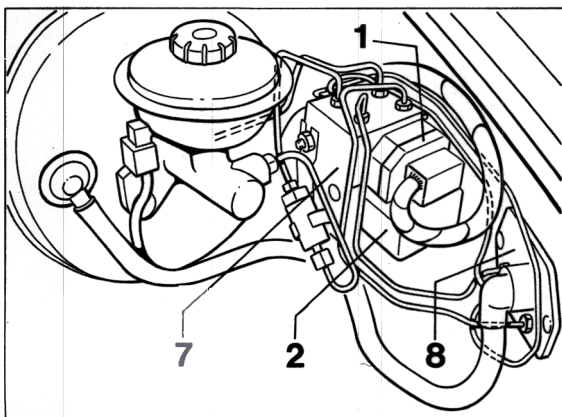

181 - 96

Diagnosis and system tests on both systems are carried out with the **Porsche System Tester 2**.

Differences between ABS 5.3 and ABS/TC 5.3

ABS 5.3 = **3-channel system**
(diagram: see Page 0 - 11).

ABS/TC 5.3 = **4-channel system**
(diagram: see Page 0 - 13).

The essential **distinguishing features** between ABS and ABS/TC are:

Number of brake lines at intermediate piece (No. 8 / Figure 181 - 96):

ABS 5.3	=	3 brake lines
ABS/TC 5.3	=	4 brake lines

TC off switch for switching driving stability control on and off is not available on vehicles with Solo ABS (ABS 5.3)

TC (ASR/ABD) warning light and TC (ASR/ABD) function light (information light) in vehicles **with ABS/TC**. These lights light up when the ignition is switched on (lamp check). These lights are **not allocated** in the instrument cluster in vehicles **with ABS 5.3** (Solo ABS).

A figure showing the warning lights and function light is shown on Page 0 - 14.

ABS 5.3 (3-channel system) system description

ABS operation

The ABS control unit receives a signal from the brake-light switch and the AC voltage signals from the four speed sensors. These signals are converted into digital wheel-speed signals independently of each other by two microprocessors. The wheel slip (approximately proportional to the computed vehicle reference speed) is formed from these wheel-speed signals.

If vehicle deceleration and excess slip are detected at a wheel, the pressure-holding phase is initiated, i.e. the inlet valve for the relevant wheel is closed to prevent a further increase in pressure. If in spite of the pressure being held constant the wheel tends to continue to lock up, the pressure in the wheel cylinder is reduced. For this purpose, the outlet valve is opened and the brake fluid is pumped back to the brake master cylinder via the return pump (pressure-reduction phase) until the wheel turns again. Then, depending on the control cycle, further appropriate cycles are initiated.

This function and the input signals are continuously monitored. If a fault is detected, the control unit switches the ABS function off, switches on the ABS warning light and stores the fault in a non-volatile memory in the control unit.

In addition, whenever a journey is begun and a speed of 6 km/h is exceeded, a test programme is started. The solenoid valves and the pump motor are electrically actuated and checked. If a fault is detected, the control unit switches the ABS function off, the ABS warning light is switched on and the fault is stored.

Diagram: ABS 5.3 (3-channel system)

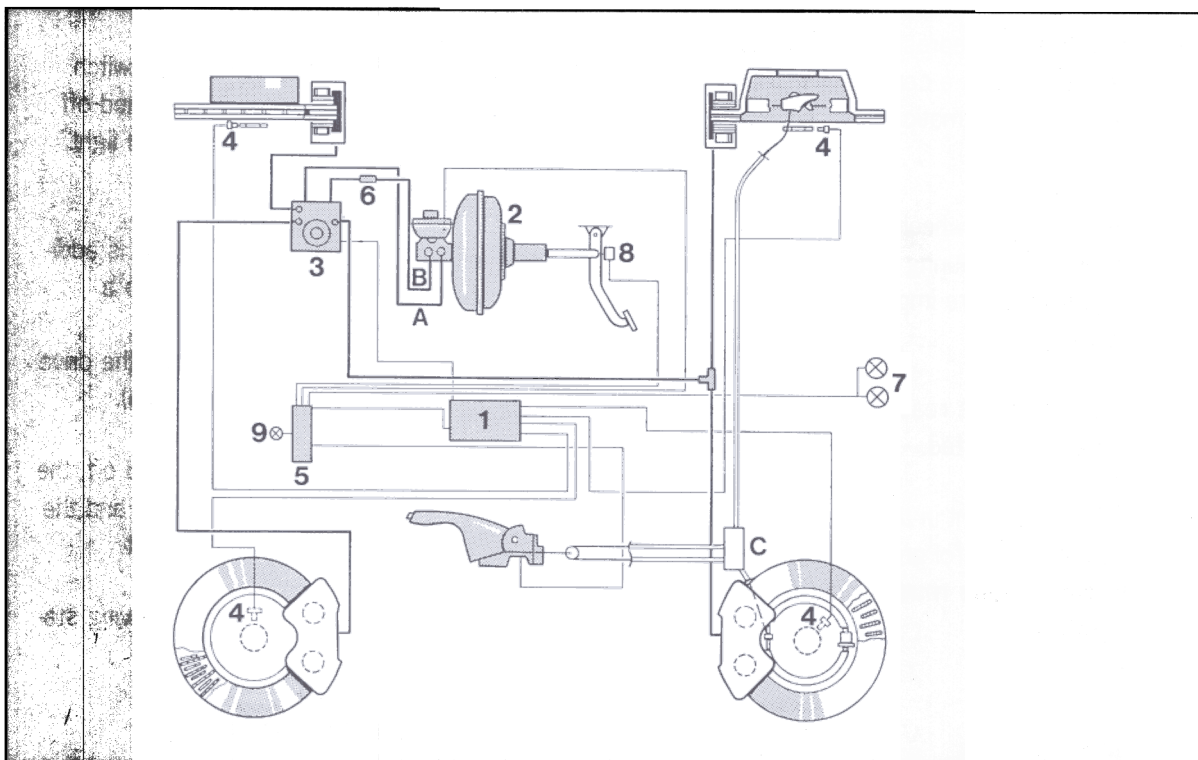

1 – ABS control unit *

2 – Brake unit (brake booster with tandem brake master cylinder)

3 – ABS hydraulic unit * (3 hydraulic outputs)

4 – ABS speed sensor

5 – Central Information System

6 – Brake proportioning valve (1x)

7 – Brake light

8 – Brake-light switch

9 – ABS warning light (yellow)

A = Front-axle braking circuit

B = Rear-axle braking circuit

C = Handbrake cable deflection box

Control unit, hydraulic unit, pump-motor relay and valve relay **form a unit** that is located next to the brake master cylinder.

ABS / TC 5.3 (4-channel system) system description

Note

Traction Control (TC) represents an extension of the ABS system and is a combination of anti-slip control (ASR) and Automatic Brake Differential (ABD).

TC prevents the drive wheels from spinning when moving off and during acceleration. Driving stability and traction are improved over the entire speed range.

Traction Control (TC) is ready for operation whenever the engine is started.

The TC information light in the instrument panel lights up during a control process **and warns that the driving style must be adapted to road conditions.**

Operation

Driving stability control:

If Traction Control (TC) detects that a certain speed difference between the wheels has been exceeded (wheel spin), engine power is automatically reduced.

Brake control:

In addition to reducing the engine power (driving stability control), the TC (via the ABD) brakes the drive wheel that is spinning.

Since this control requires the drive wheels to be individually controlled, the **ABS/TC system is a 4-channel system.**

Switching off driving stability control

Press the "TC OFF" logo of the rocker switch. Driving stability control cannot be switched off during a TC control process (information light on).

One-sided wheel spin on the drive axle is additionally prevented by brake control up to a speed of 100 km/h.

Driving stability is not monitored, since the drive wheels can spin at the same speed (slip).

When driving stability control is switched off, the TC warning light in the instrument panel and the indicator light in the rocker switch are lit.

It can be advantageous to switch off driving stability control:

- on a loose surface and in deep snow
- when "rocking" the vehicle free
- when using snow chains.

Switching driving stability control back on

Press the indicator light in the rocker switch.

Driving stability control cannot be switched on again during a TC control process (information light on).

Diagram: ABS / TC 5.3 (4-channel system)

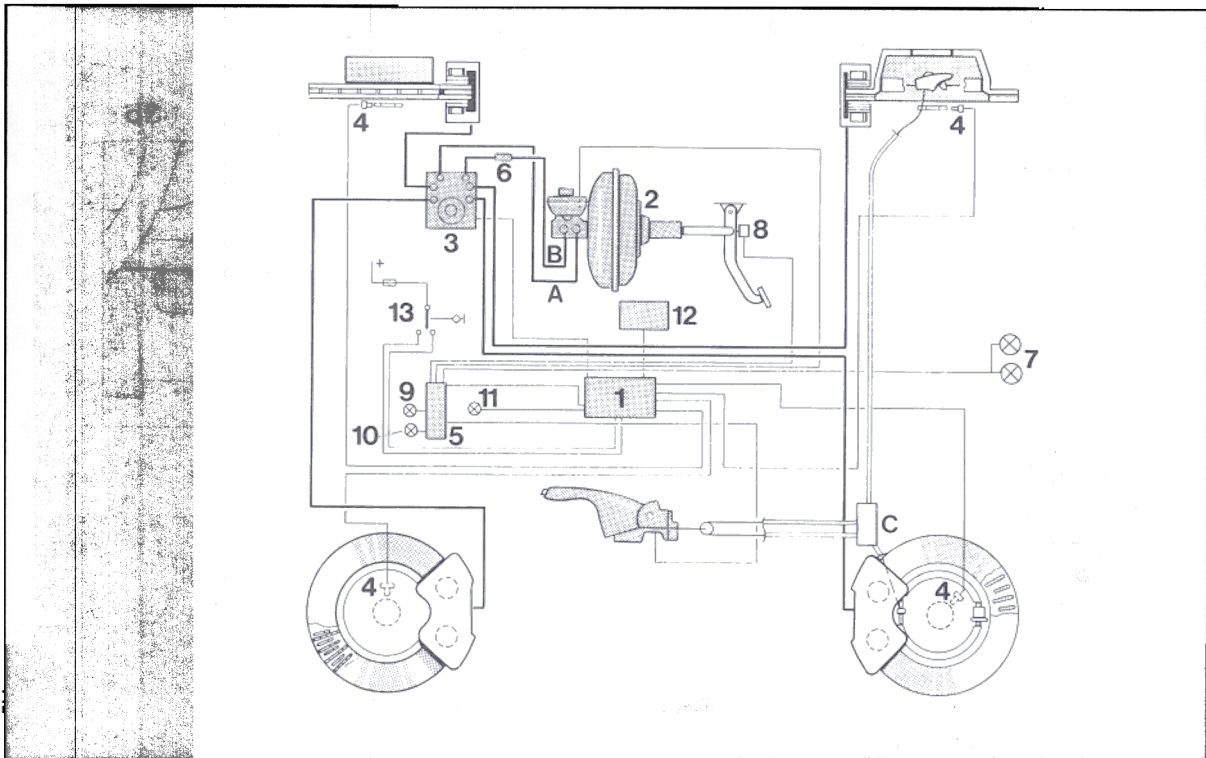

- | | |
|--|--|
| 1 – ABS/TC control unit * | 7 – Brake light |
| 2 – Brake unit (brake booster with tandem brake master cylinder) | 8 – Brake-light switch |
| 3 – ABS/TC hydraulic unit *
(4 hydraulic outlets) | 9 – ABS warning light (yellow) |
| 4 – ABS speed sensor | 10 – TC warning light (TC/yellow) |
| 5 – Central Information System | 11 – TC function light (green) |
| 6 – Brake proportioning valve (1x) | 12 – DME control unit |
| | 13 – TC rocker switch |
| | A = Front-axle braking circuit |
| | B = Rear-axle braking circuit |
| | C = Handbrake cable deflection box |

Control unit, hydraulic unit, pump-motor relay and valve relay form a single unit that is located beside the brake master cylinder.

Component arrangement (ABS 5.3 and ABS/TC 5.3)

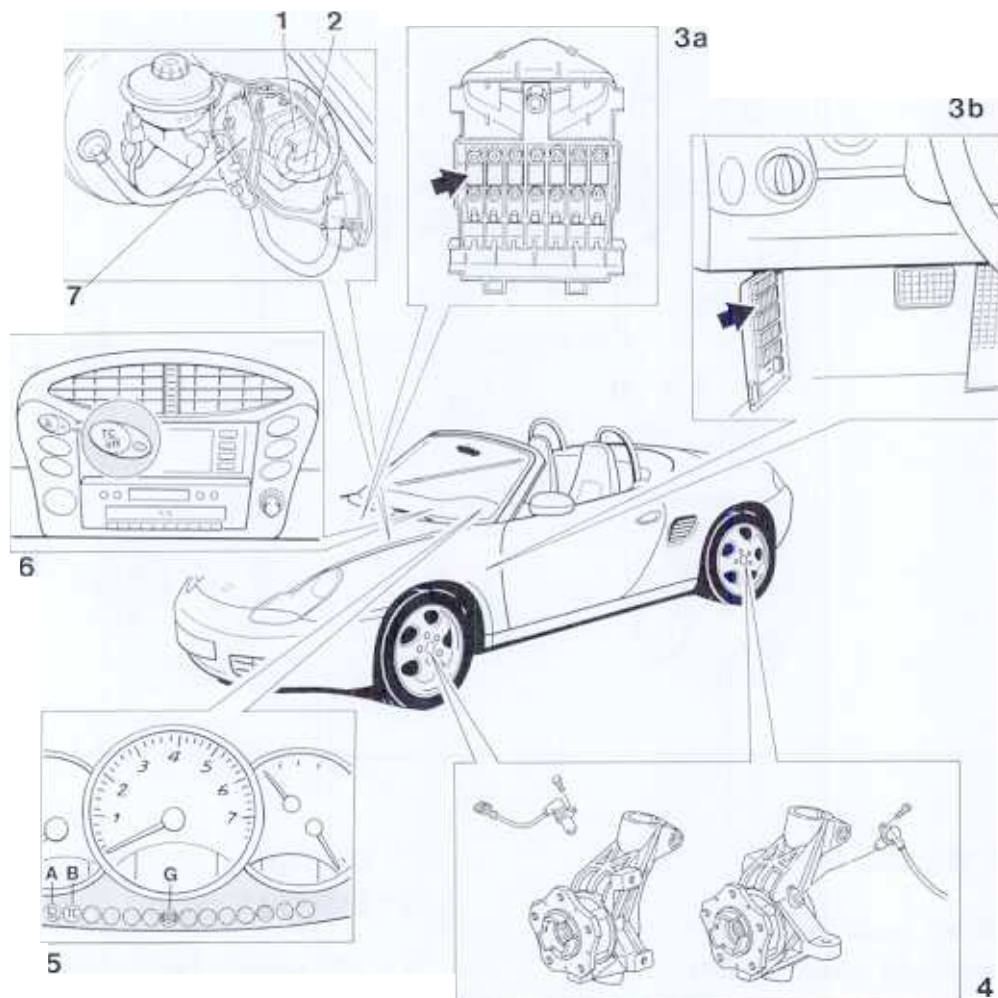

1. Control unit (ABS 5.3 and ABS/TC 5.3)

2. Relays (engine and valve relays)

3. Fuses

3a = 50-A fuse in the current distributor

3b = 15-A fuse F 2/9 (Field 2, No. 9)

3b = 15-A fuse F 2/1 (Field 2, No. 1)

4. Speed sensors

5. Warning and information lights

A = TC information light

B = TC warning light

G = ABS warning light

6. TC (OFF) rocker switch with light

7. Hydraulic unit

0 Body - general

Diagram: Passenger safety compartment

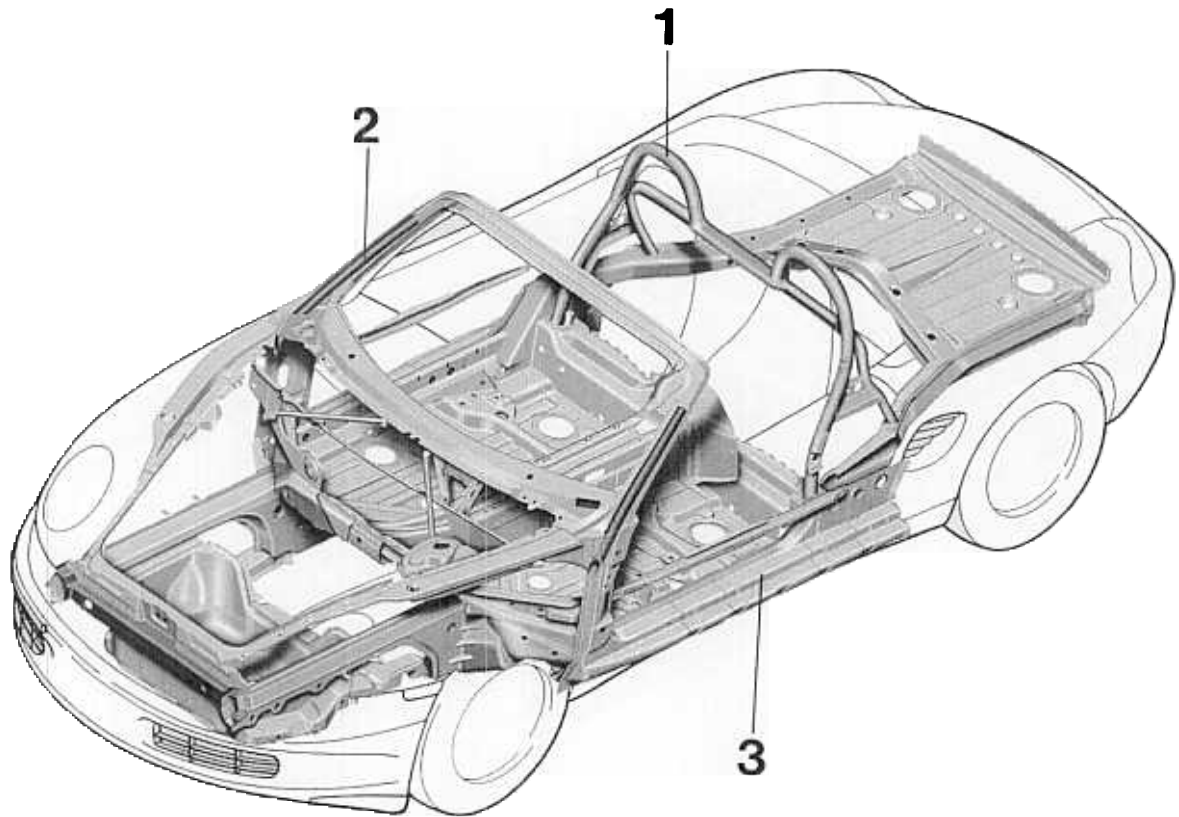

639 - 96

- 1 Roll-over bar
- 2 Reinforcing pipe in the A pillar
- 3 The body is manufactured from stronger sheet steel

Body of stronger sheet steel

The indicated body parts are made by welding together plates of differing thickness and characteristics and then deep-drawing these parts. In their crash behaviour, these body parts are distinguished by their high energy absorption.

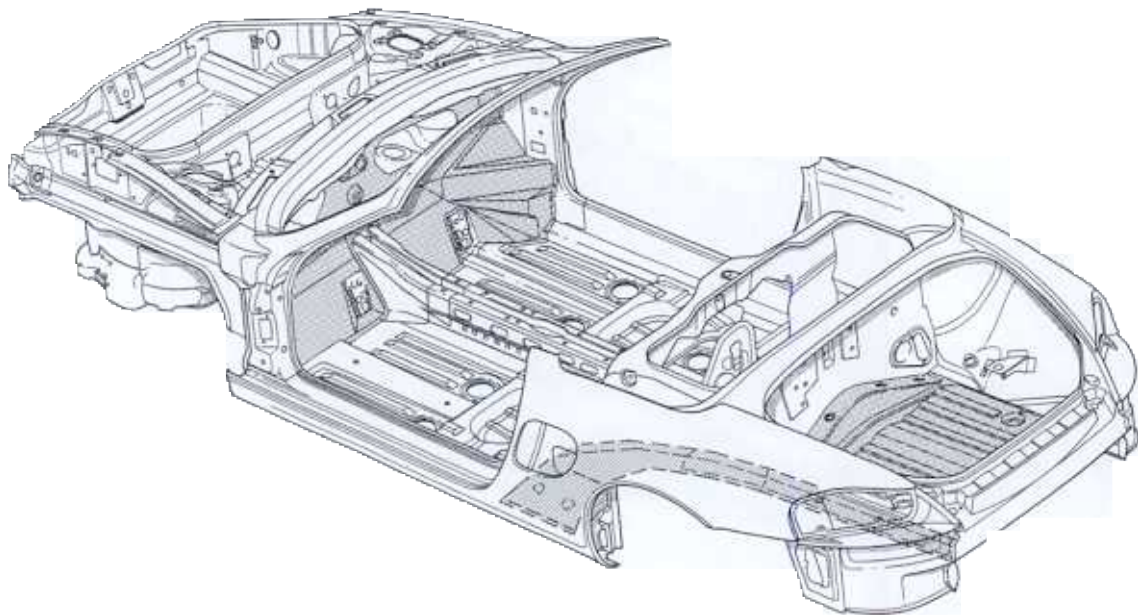

677 - 96

Body of stronger sheet steel

The indicated body parts attain their final strength **only** under the temperature effects of the production stage of cathodic immersion painting and drying.

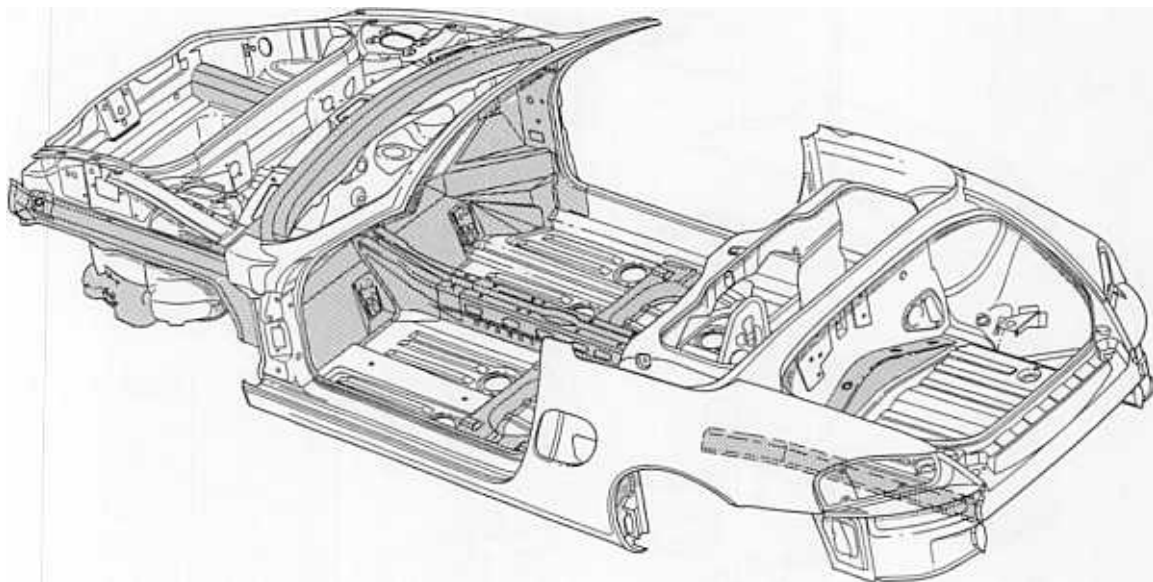

678 - 96

Body repairs by reshaping are not possible if these body parts have been excessively deformed. Here, the repair must be made by the use of new parts or sectional repairs.

The use of stronger steels for the body has consequences for body repair work. For this reason, use only

"Original Porsche Spare Parts"

for body repair work!

Overview: plastic body components

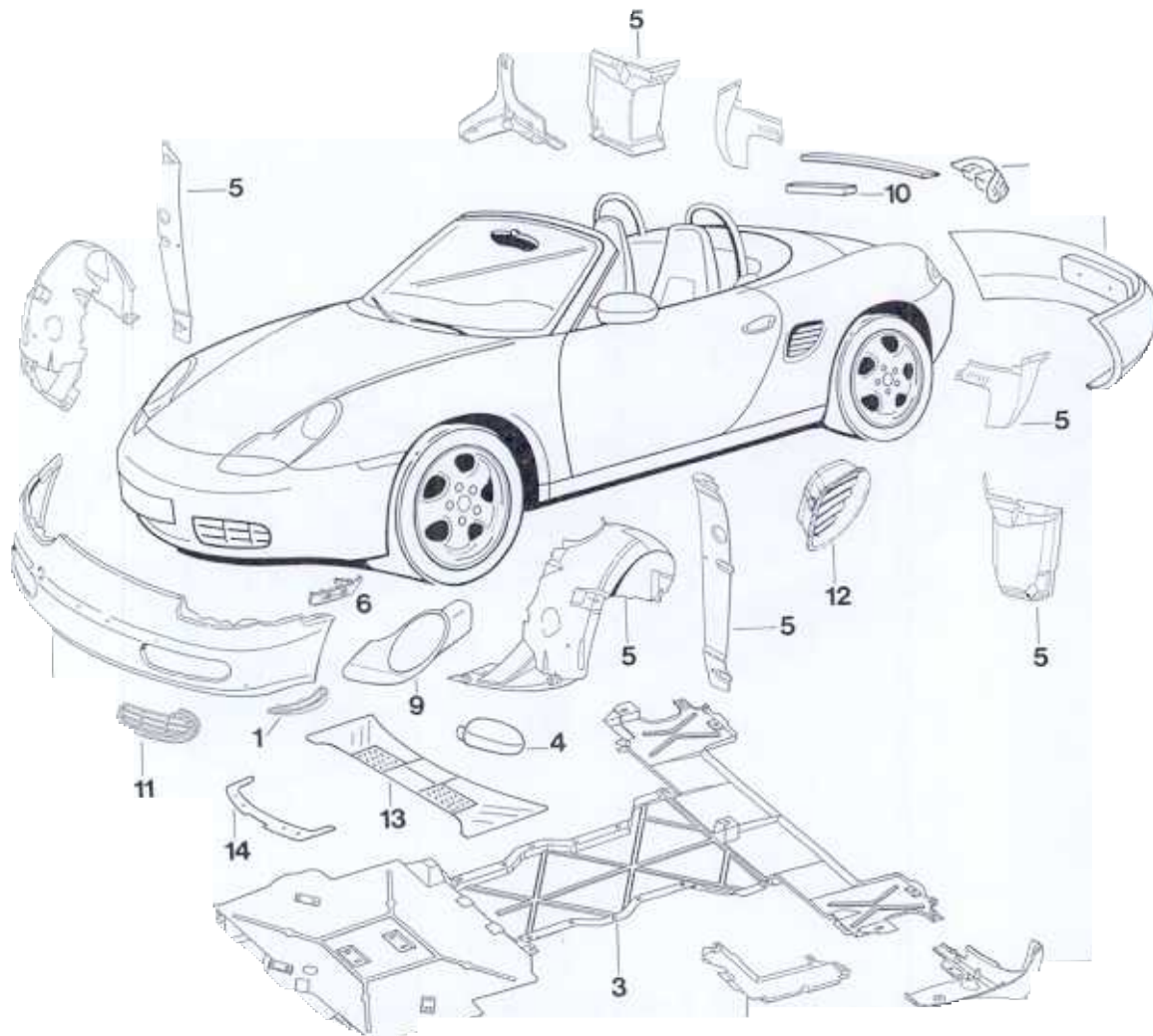

Plastic body components

No.	Component	Plastic
	Front end	PP+EPDM
2	Rear end	PP+EPDM
3	Underside panel	PP
4	Housing for rear-view mirror	PC+ABS
5	Wheel housing liners	PP
6	Front direction indicator light Direction indicator light housing Direction indicator light lens	ABS PMMA
7	Rear spoiler	PA
8	Rear direction indicator light Direction indicator light housing Direction indicator light lens	ABS PMMA
9	Headlight Headlight housing Headlight lens	PP PC
10	Third brake light	PMMA
11	Front air inlet grille	PP+EPDM
12	Rear air inlet Air inlet housing Air inlet grille	PPS+PC PPS+PC
13	Front radiator tank cover	PP
14	Front luggage compartment cover	PP

Water drainage plan

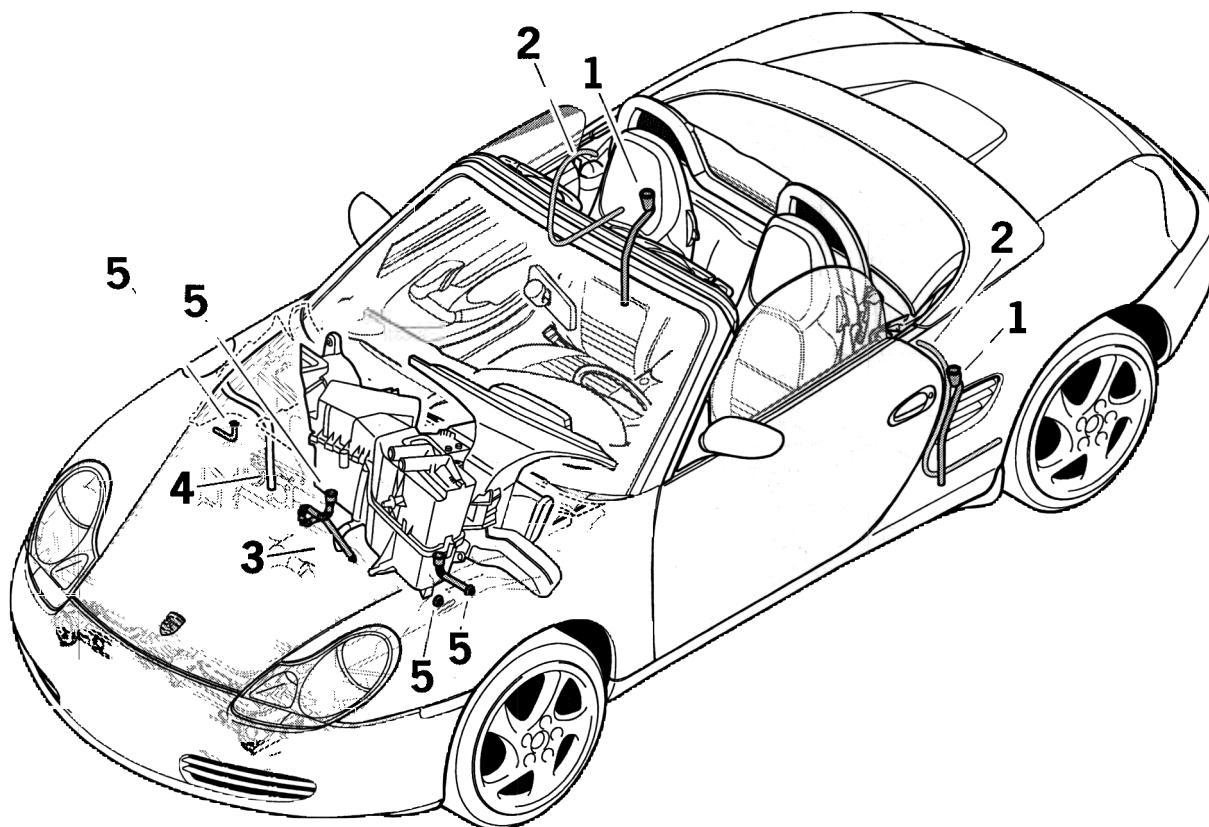

289_99

- | | | | |
|---|---------------------------------------|---|---|
| 1 | Water drainage: water collection tray | 2 | Water drainage: sealing channel on rear side section |
| 3 | Water drainage: tank tray | 4 | Water drainage: evaporator of heating and air-conditioning system |
| 5 | Water drainage: radiator tank | | |

Component arrangement – airbag

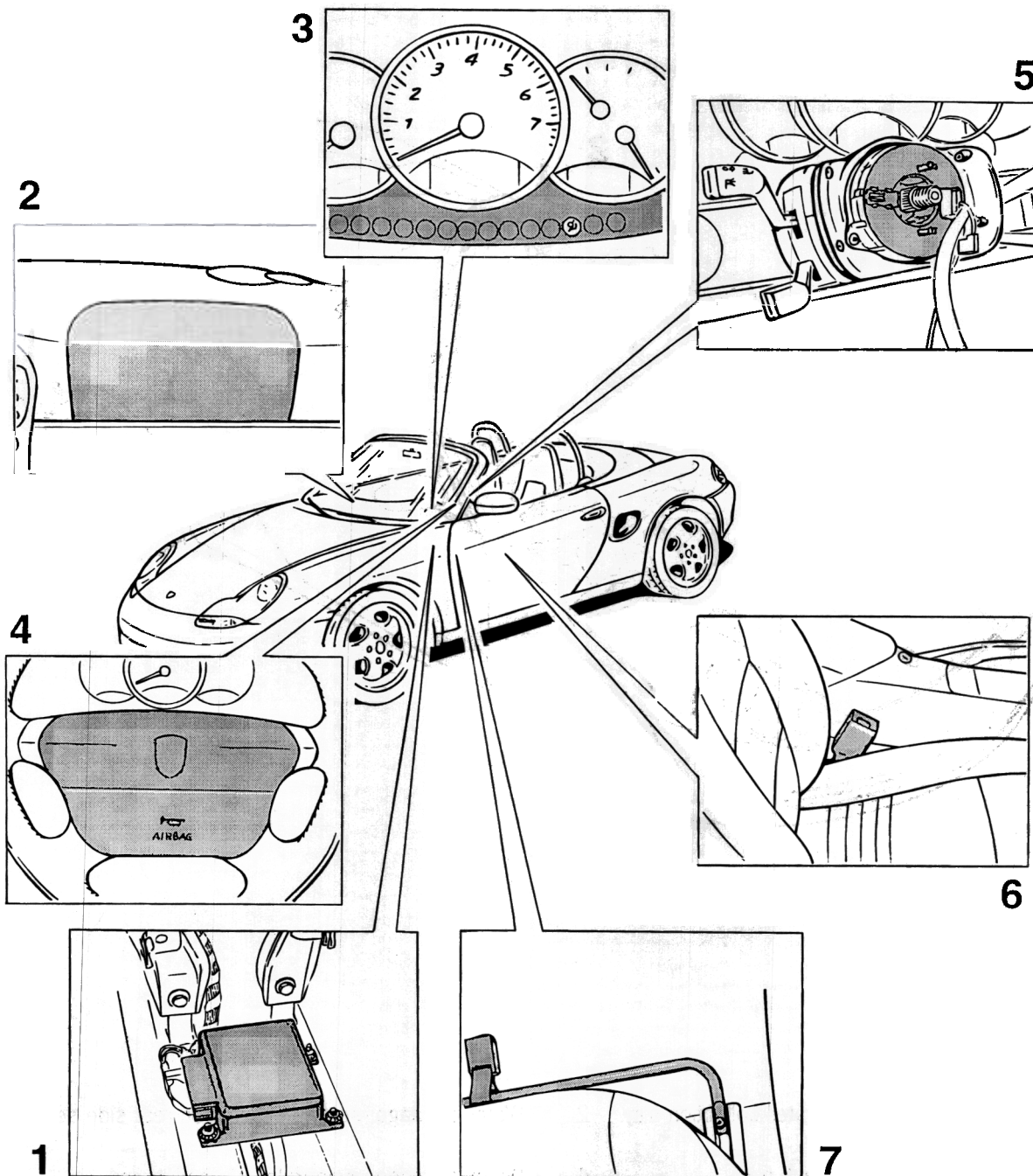

105_96

Component arrangement - airbag

- 1 Triggering unit
- 2 Passenger airbag unit
- 3 Warning light
- 4 Driver's airbag unit
- 5 Contact unit
- 6 Buckle, driver/passenger
- 7 Seat occupancy detection, passenger's side
- 8 Plug connection, child restraint system

0 Electrical system - general

Fuse assignments

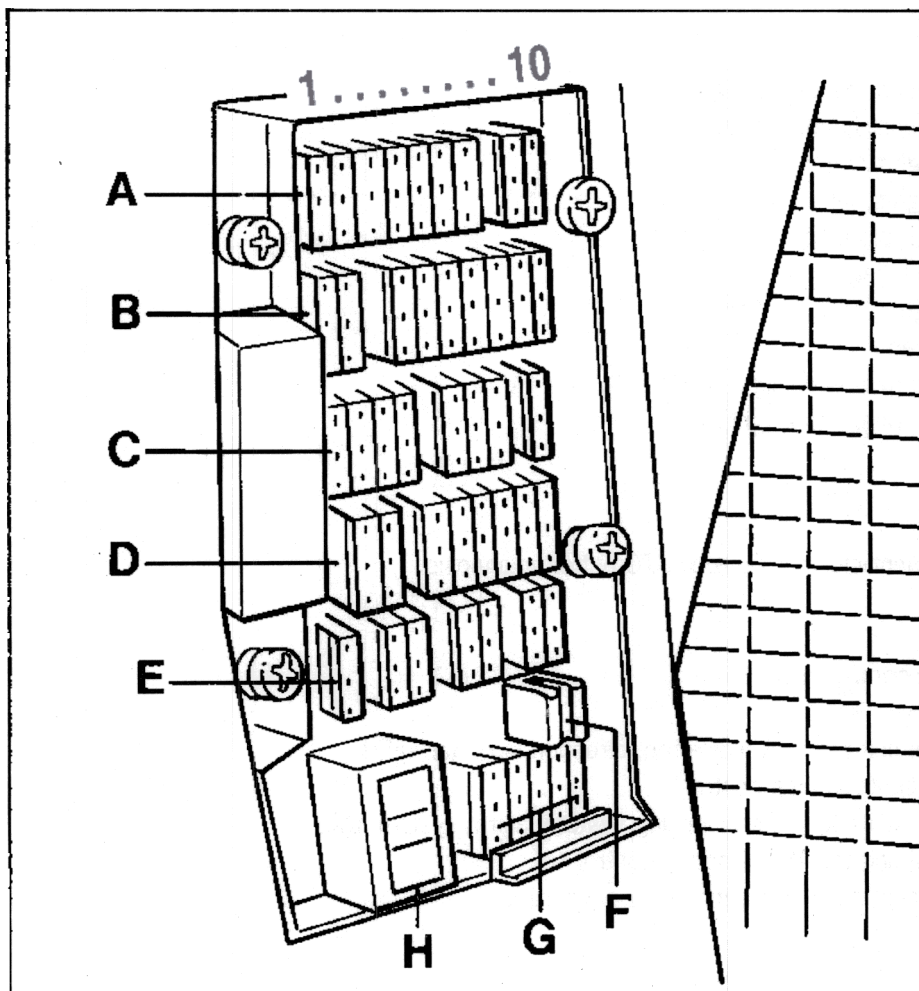

45296g

- A to E: Fuses (rows A - E)
- F: Gripper
- G: Replacement fuses
- H: Switch for spoiler

Fuse assignments

No.	Load	Amperage rating
Row A		
	High beam headlight, right	7.5
2	High beam headlight, left	7.5
3	Side lights, right	7.5
4	Side lights, left	7.5
5	Number plate light	7.5
6	Seat heating	25
7	Fog lights, rear fog light	25
8	Not used	
9	Dipped beam headlight, right	7.5
10	Dipped beam headlight, left	7.5
Row B		
	Instrument cluster, Tiptronic, TC button, diagnosis	15
2	Radio	7.5
3	Horn	25
4	Engine-compartment fan	15
5	Reversing lights	7.5
6	Control unit for convertible top, direction indicator lights	15
7	Brake lights, cruise control	15
8	Control units for central locking system, alarm system, DME	15
9	Control unit for ABS, traction control	15
10	Instrument cluster, diagnosis, door mirrors	15
Row C		
	DME relay	25
2	Ignition relay, oxygen sensors	30
3	Control unit for central locking system, alarm system, power windows	15
4	Fuel pump relay	25
5	Not used	
6	Windshield wipers	25
7	Terminal X , control wiring	7.5
8	Radiator fan 2	30
9	Headlight washer	25
10	Radiator fan 1	30

No.	Load	Amperage rating
Row D		
1	Power windows	30
2	Door mirrors, heated rear window	30
3	Convertible top drive	30
4	Not used	
5	Cigarette lighter	15
6	Heater relay	30
7	Switch for hazard warning lights, DME control unit	15
8	Retractable spoiler	15
9	Sound package	15
10	Slot for additional equipment	
	Caution! Max. 5 A	7.5

Row E

	Terminal 86 S; instrument cluster; radio; control units for central locking system, alarm system, airbag	7.5
2	Not used	
3	Backrest adjustment, left	30
4	Backrest adjustment, right	30
5	Not used	
6	Terminal 30, telephone	7.5
7	Air conditioning system	7.5
8	Not used	
9	Terminal 15, telephone	7.5
10	Tiptronic control unit	15

Note

If the power windows malfunction, check fuse C3 (15 A) in addition to fuse D1 (30 A).

Component arrangement, alarm system

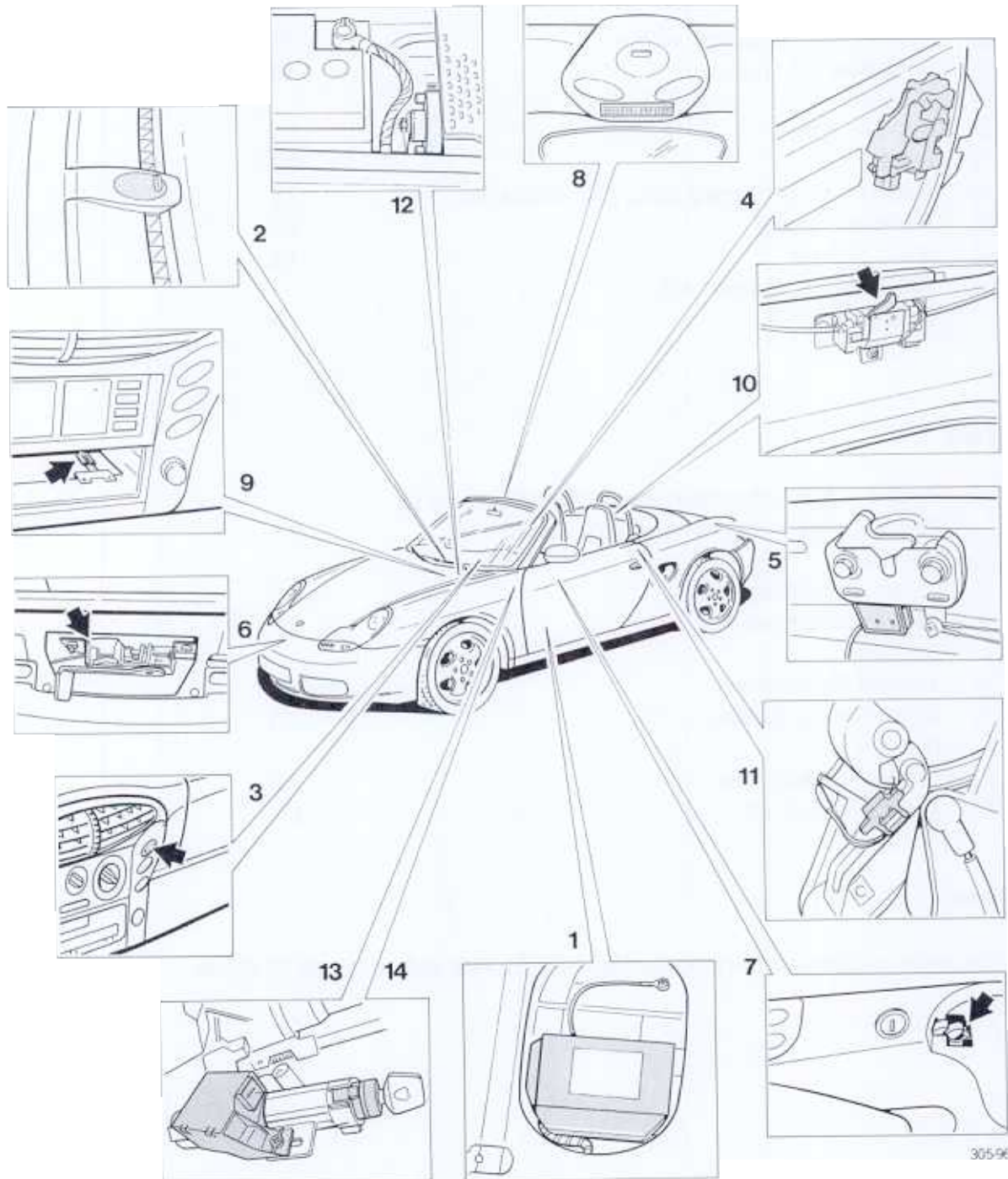

Component arrangement, alarm system

- 1 Control unit
- 2 Alarm readiness light
- 3 Central locking button
- 4 Door lock module
- 5 Switch, rear luggage-compartment lid
- 6 Switch, front luggage-compartment lid
- 7 Switch, oddments tray
- 8 Passenger compartment monitoring sensor
- 9 Alarm contact, radio
- 10 Switch, convertible-top compartment lid
- 11 Switch, convertible top closed
- 12 Alarm horn
- 13 Signal converter
- 14 Transponder coil

0 Technical data**Engine**

Engine type:		M 96/20
Number of cylinders		6
Bore	mm	85.5
Stroke	mm	72
Displacement	cm ³	2480
Compression ratio		11.0 1
Max. engine power as per 80/1269/EWG	kW	150
as per SAE J 1349	HP	201
at engine speed	rpm	6000
Max. torque as per 80/1269/EWG	Nm (ftlb.)	245 (181)
at engine speed	rpm	4500
Max. litre output as per 80/1269/EWG	kW/l, HP/l	60.48/82.26
Idle speed - manual transmission	rpm	790
Tiptronic sel. lever in P or N	rpm	750
Tiptronic sel. lever in drive position	rpm	790
and A/C on	rpm	800
Rpm limitation at	rpm	6700
Engine weight		
Manual transmission	kg	182.2
Tiptronic transmission	kg	172.7

Valve control	DOHC with camshaft adjustment (VarioCam)
Valve arrangement per cylinder	2 inlet, 2 outlet, suspended parallel V-arrangement
Valve clearance	Hydraulic valve clearance compensation
Valve timing with 1 mm valve travel	Inlet opens 15° after TDC Inlet closes 46° after BDC Outlet opens 38° before BDC Outlet closes 7° before TDC

Engine cooling

Type	Liquid cooling, two electric fans
------	-----------------------------------

Engine lubrication

		Integrated dry sump
Oil cooling		Via oil-water heat exchanger
Oil pressure at 5000 rpm		
Oil temperature 90 °C	bar	approx. 5
Oil consumption	l/1000 km	up to 1.5

Fuel system

		DME 5.22 with sequential fuel injection
Fuel delivery		1 electr. fuel pump
System pressure without vacuum	bar	3.6 4.0
Fuel RON/MON		at least 98/88

**Fuel consumption
as per 93/116/EG**

		Manual transmission	Tiptronic
City	l/100 km	14.3	15.8
Highway	l/100 km	7.1	8.1
Overall	l/100 km	9.7	10.9
Target CO ₂ value	g/km	239	263

Emission control

Oxygen sensing and three-way catalytic converter (metallic substrate)

Electrical system

Nominal voltage	V	12
Alternator output	W/A	1680/120
Battery, manual transmission	Ah/A	60/280
Battery, Tiptronic	Ah/A	70/320

Ignition DME 5.22, with static high-voltage distribution and cylinder-selective knock regulation

Ignition sequence 1 - 6 - 2 - 4 - 3 - 5

Spark plugs

Bosch		FR 7 LDC 4
Beru		14 FR 7 LDU
Electrode gap	mm	0.8 + 0.1

Power transmission

Clutch	Single-plate dry clutch with thrust plate, pressed version, two-mass flywheel
Thrust plate	GGG 60
Drive plate	Rigid 240

Manual transmission

Transmission ratios	G 86/00
1st gear	3.50
2nd gear	2.12
3rd gear	1.43
4th gear	1.03
5th gear	0.79
R. gear	3.44
Final drive	3.89
Transmission weight filled with oil	kg 49.2

Tiptronic	A 86/00
Torque converter ø	mm 254
Moving-off ratio	2.29 : 1
Stall speed	rpm 2700 - 400

Transmission ratios:

1st gear	3.66
2nd gear	2.00
3rd gear	1.41
4th gear	1.00
5th gear	0.74
R. gear	4.10
Final drive	4.21
	(Intermediate gearbox 1.25/axle 3.36)
Transmission weight filled with oil	kg 112.5

Running gear**Front axle**

Spring wire \emptyset (sport-type running gear)	mm	10.25 ... 13.18 (10.84 ... 13.90)
Coil \emptyset (sport-type running gear)	mm	90.5 ... 186.5 (91.68 ... 186.5)
Turns		4.05 (4.05)
Tube-type stabiliser \emptyset (sport-type running gear)	mm	23.1 x 3.4 (23.6 x 3.5)

Steering

Steering wheel \emptyset	mm	380
Steering transmission ratio (RHD vehicle)		1 : 16.9
Lock-to-lock turns (RHD vehicle)		2.98
Turning circle \emptyset	m	10.9

Rear axle

		Manual transmission	Tiptronic
Spring wire \emptyset (sport-type running gear)	mm	12.6 (13.30)	12.67
Coil \emptyset (sport-type running gear)	mm	148.5 (148.5)	148.5
Turns		4.55 (4.40)	4.55
Tube-type stabiliser \emptyset (sport-type running gear)	mm	18.5 x 2.5 (19.6 x 2.6)	18.5 x 2.5

Wheel alignment, front axle

	RoW	USA
Toe-in (total)	+ 5'± 5'	+ 5'± 5'
Camber, standard	- 10'± 30'	+ 5'± 30'
Camber, sport-type running gear	- 15'± 30'	
	max. difference bet. le. & ri. 20'	
Caster	8° ± 30'	8° ± 30'
	max. difference bet. le. & ri. 40'	
Toe difference angle at 20° steering angle	- 1° 50'± 30'	- 1° 50' ± 30'
Sport-type running gear	- 2° 20'± 30'	- 2° 20'± 30'

Wheel alignment, rear axle

Toe-in (per wheel)	+ 5'± 5'	+ 5'± 5'
Camber, standard	- 1° 20'± 30'	- 1° 20'± 30'
Camber, sport-type running gear	- 1° 30'± 30'	- 1° 30' ± 30'

Brake system

Operating brake Hydraulic 2-circuit brake system, distribution per axle. Vacuum brake booster, ventilated brake discs at front and rear axles.
ABS standard, Traction Control via M-number.

Brake booster	Ratio	3.85 : 1
Master brake cylinder ø		
front	mm	23.81
rear	mm	23.8
Pressure regulator		
Activation pressure	bar	25
Reduction factor		0.46

Piston \varnothing in brake caliper		
front	mm	36 and 40
rear	mm	28 and 30
Brake disc \varnothing		
front	mm	298
rear	mm	292
Effective brake disc \varnothing		
front	mm	250
rear	mm	240.6
Brake disc thickness		
front	mm	24
rear	mm	20
Effective total pad area	cm ²	412
Parking brake		Acts mechanically on both rear wheels with deflection
Brake drum \varnothing	mm	164
Brake shoe width	mm	20
Brake pad area per wheel	cm ²	60
Wheels and tyres		
Tyre size, front - on wheel		205/55 ZR 16 - 6 J x 16 H2 ET 50
Tyre size, rear - on wheel		225/50 ZR 16 - 7 J x 16 H2 ET 40
or		
Tyre size, front - on wheel		205/50 ZR 17 - 7 J x 17 H2 ET 55
Tyre size, rear - on wheel		255/40 ZR 17 - 8.5 J x 17 H2 ET 50
Winter tyres		
Tyre size, front - on wheel		205/55 R 16 89T M+S - 6 J x 16 H2 ET 50
Tyre size, rear - on wheel		225/50 R 16 92T M+S - 7 J x 16 H2 ET 40
Spare wheel		High-pressure tyre T105/95 R 17
Tyre pressure		
front	bar	2.0 (29 psi)
rear	bar	2.5 (36 psi)
Spare tyre	bar	4.2 (60 psi)

Dimensions and weights

		RoW	USA
Length	mm	4315	4340
Width	mm	1780	
Height	mm	1290	
Wheel base	mm	2415	
Track width, front	16 inches mm	1465	
	17 inches mm	1455	
Track width, rear	16 inches mm	1528	
	17 inches mm	1508	
Ground clearance at permissible gross weight	mm	95	105
Ramp angle		12°	13
Overhang angle, front		12°	13
	rear	16.5°	16.5°

Empty weight as per DIN 700 20

		Manual transmission	Tiptronic
Front	kg	585	585
Rear	kg	665	715
Total	kg	1250 – 1320	1300 – 1370
Permissible axle load			
Front	kg	775	775
Rear	kg	895	895
Permissible gross weight	kg	1560	1610
Roof load with Original Porsche			
Roof Transport System	kg	75	75

Filling capacities

Engine oil quantity		Oil change with oil filter approx. 8.25 Oil change without oil filter approx. 7.75
Manual transmission with final drive		2.25 (SAE 75 W 90 Burmah Oil TAF 21)
Tiptronic oil quantity Automatic section		9.5 (ATF ESSO LT 71141)
Oil quantity, final drive		0.8 (GL5 SAE 90 or GL5 SAE 75 W 90 or Burmah SAF - AG 4/1016)
Fuel tank		57, of which approx. 9 l reserve
Brake fluid reservoir		0.4 (brake fluid Super DOT 4)
Fluid reservoir for power steering		1.0 (Pentosin CHF 11 S)
Windshield/headlight washer tank		2.5 7.0
Refrigerant R 134a	g	850
Refrigerant oil	cm ³	195 ± 15

Performance

Top speed		Manual transmission	Tiptronic
	km/h / mph	240/149	235/146

Acceleration

0 - 100 km/h	s	6.9	7.6
0 - 160 km/h	s	16.5	18.9
0 - 100 mph	s	16.5	18.9
0 - 60 mph	s	6.7	7.4
Kilometre from standing start	s	27.4	28.0
1/4 mile from standing start	s	15.1	15.5

Elasticity

80 - 120 km/h, 4th gear	s	7.3	8.2
80 - 120 km/h, 5th gear	s	11.4	12.7
100 - 200 km/h, 5th gear	s	33.9	39.8

Specific power	kg/kW	8.3	8.7
	kg/HP	6.1	6.3

0 Plug-in couplings for pipelines

Different plug-in couplings are used for various applications (see Allocation).

Allocation of the plug-in couplings / pipelines*

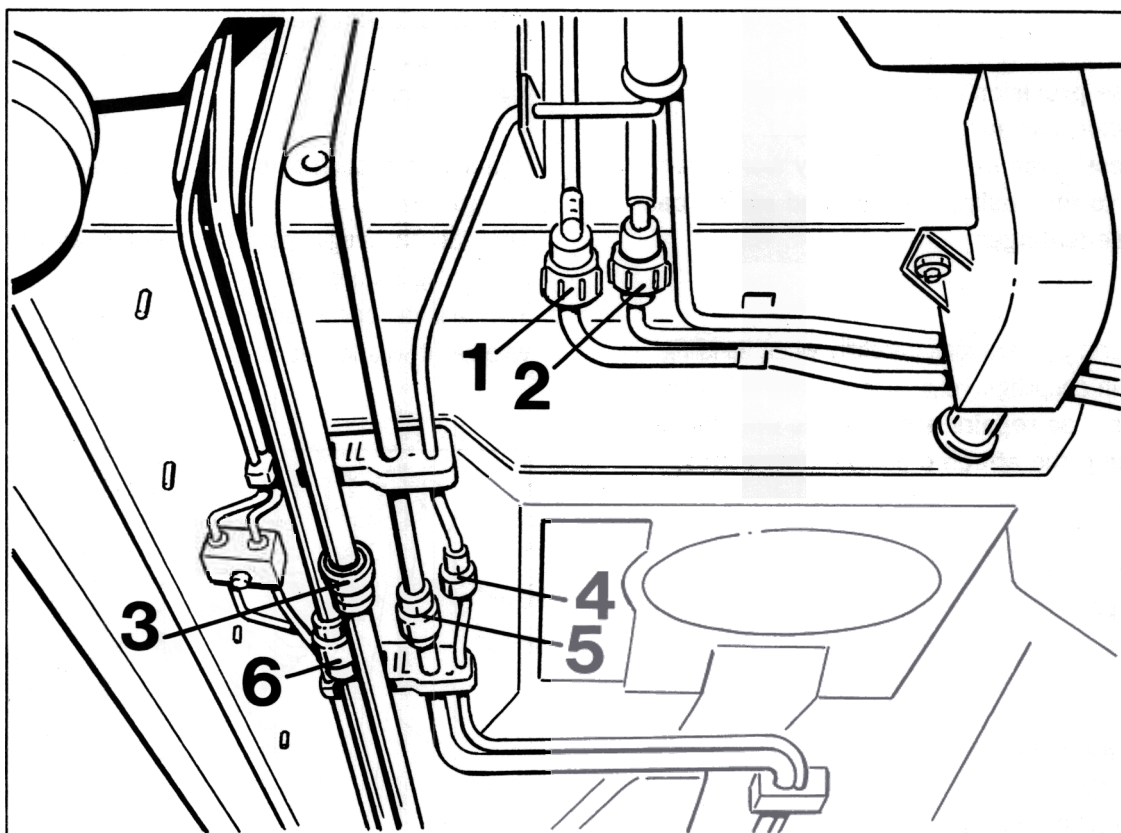

- 1 = Fuel line with 2 unlocking buttons
- 2 = Fuel line with 1 unlocking button
- 3 = Vacuum line (for brake booster)
- 4 = Steering pressure line
- 5 = Steering return line
- 6 = Clutch line (hydraulic actuating system / blue line)
- = Steering return line on the hydraulic pump (see Figure on Page 0 - 46)

* All listed plug-in couplings are used at various installation locations and on different components, e.g. on the carbon canister and on the oil dipstick guide tube.

Opening and joining plug-in couplings

Important notes

Plug-in couplings are components that permit simple, fast and precise connection of pipelines.

These precision components must be handled carefully during repairs. Excess force during assembly work, damage to the sealing surface and soiling can cause leakage.

Perform preparations carefully when handling plug-in couplings - e.g. cleaning and fitting the plugs - **as repairs are possible only by replacing the affected line in most cases.**

After separating the plug and socket piece, carefully protect them against dirt and scratches with caps.

Join the plug-in connection only in a **straight line**. Never use excessive force. Pull slightly to make sure the connection is locked properly.

Fuel lines

Operate unlocking button(s) (press) - see arrows - and simultaneously separate the pipelines by pulling them apart.

Join the connection by plugging together in a straight line.

The plug (the plug-in part) must audibly engage in the plug-in coupling.

Then pull the connection slightly to check whether it was locked properly.

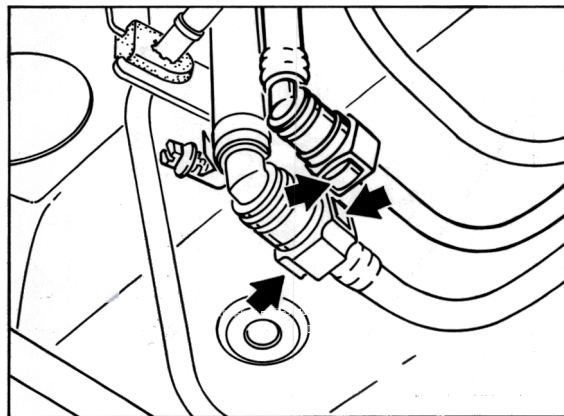

367/2 - 96

Vacuum line

In order to undo the vacuum line, **press the black unlocking ring (arrow)** and simultaneously pull the lines apart.

Join the connection by plugging together in a straight line.

Then pull the connection slightly to check whether it was locked properly.

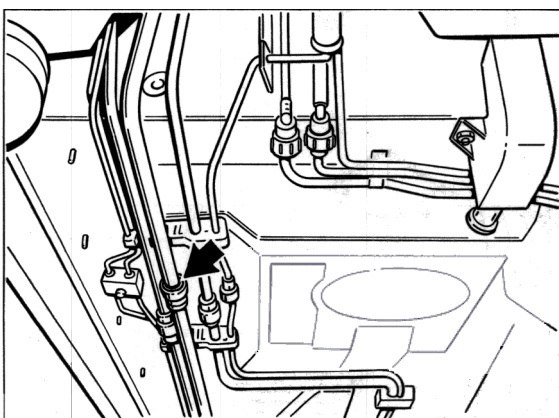

664/2 - 96

Steering pressure line and return line

The plug-in couplings are **opened** by unscrewing.

They are **joined** by plugging together.

A detailed description about opening and joining is given on Pages 48 - 13 to 48 - 16.

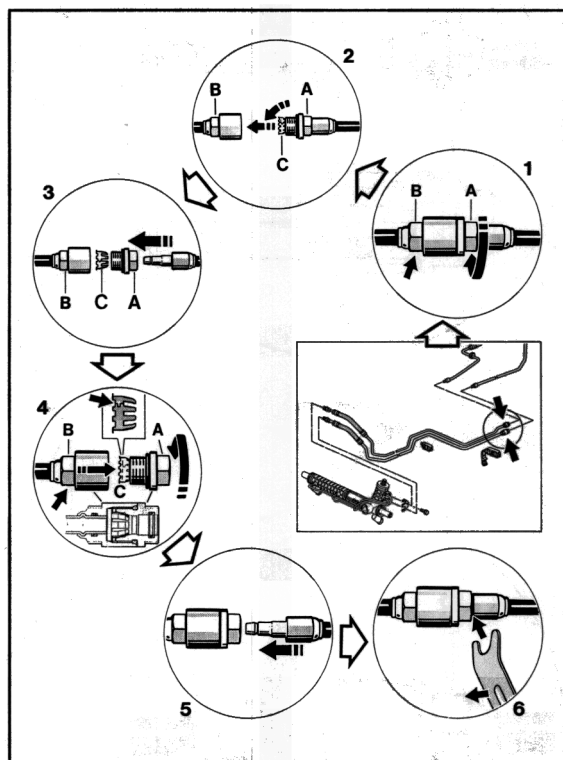

663 - 96

Clutch line

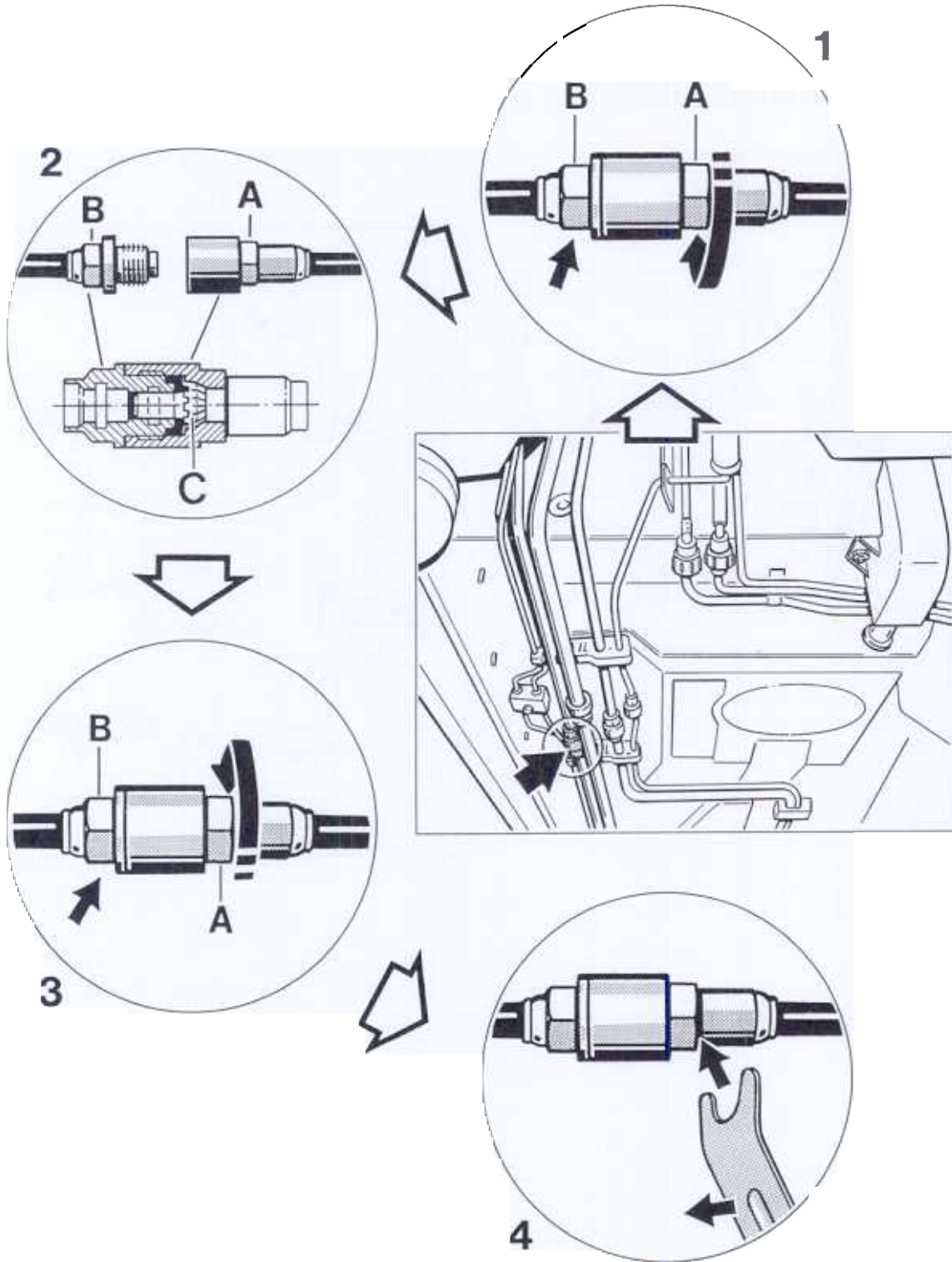

Note

The plug-in coupling is opened by unscrewing.

Pipelines that were fitted once before are joined by screwing together (as opposed to new lines and steering lines, which are plugged together). This is necessary because **holder C** is located very deep in the threaded part of the plug-in coupling and cannot be removed with conventional workshop equipment.

No.	Procedure	Instructions
1	Open plug-in coupling.	Turn at threaded part A to open the plug-in coupling. When doing so, counter at plug-in coupling B.
2	Separate lines.	Remove lines from the retainers on the body and separate.
3	Screw together plug-in coupling.*	Turn at threaded part A when joining the plug-in coupling. When doing so, counter at plug-in coupling B.
4	Use special tool 9263 to check whether the plug-in coupling was engaged properly.	Insert special tool 9263 into the groove (arrow) and apply slight pressure on the special tool to check whether the connection is securely locked (holder is seated properly) . The plug must not slide out. If the special tool cannot be inserted into the groove of the plug, shift the plug in the plug-in coupling (pull on plug with-out using excessive force).

Note

The plug-in connection is designed so that the plug can be shifted in the plug-in coupling by approx. 1 mm in axial direction by slightly pulling or pressing.

* **On new pipelines**, the plug-in coupling - including holder C - has already been screwed together. All that remains is to insert (engage) the plug of the mating pipeline in a straight line.

Steering return line on hydraulic pump

To release the return line, press the **red unlocking ring (arrows)** and simultaneously pull the line out of the hydraulic pump.

Join by plugging together in a straight line. Then pull slightly to ensure that the connection is properly locked.

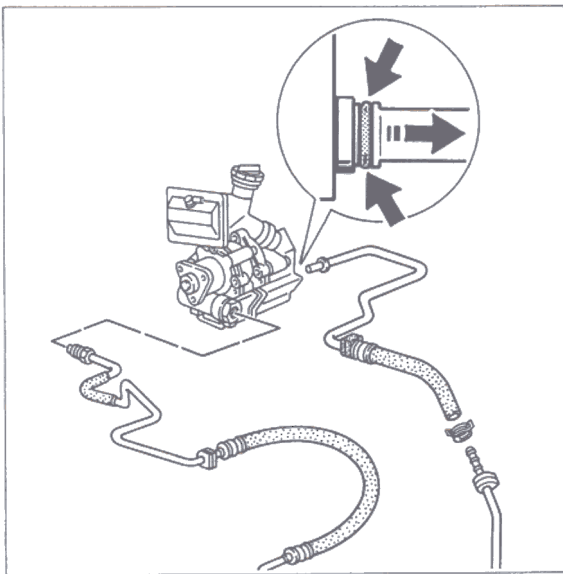

701 - 96

0 Lifting the vehicle

Lift the vehicle only at the take-up points shown in the figure. When driving onto a platform lift, make sure that there is sufficient distance between the platform lift and the vehicle.

FRONT

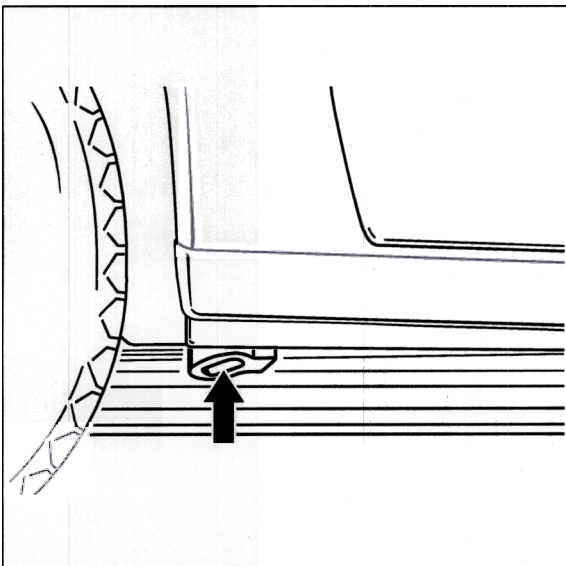

97-047

REAR

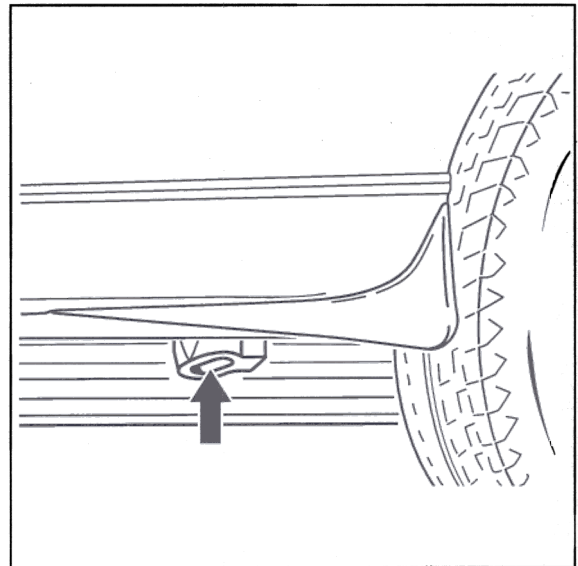

97-048

0 Electrical power supply – general

Effect of disconnection or total discharge of the battery on electrical systems in the vehicle, subsequent measures:

1. Never disconnect battery with engine running.
2. Never start engine without securely connected battery.
3. Do not use a boost charger to start the engine.
4. Whenever possible, use jump leads with over-voltage protection.
5. Always disconnect the battery terminals before carrying out welding work on the vehicle.
6. Wiring harness plugs of control modules or other electronic components must be connected or disconnected with the ignition off. Exception: vehicles with the additional equipment M 536 (alarm siren with tilt sensor).

Note concerning M 536:

In order to avoid triggering the alarm siren (installed next to the battery) of vehicles with M 536, the battery must be disconnected with the ignition on (all loads must be switched off beforehand).

Control module memories:

Values and faults stored in the control modules can be deleted if the battery is disconnected or completely discharged.

Remedy:

If possible, all fault memories should be checked and, if necessary, printed out before the battery is disconnected.

Supply voltage fault entry:

The entry "supply voltage" could be stored in various control modules if the battery has been completely discharged.

Remedy:

Delete the "supply voltage" entry from the control modules in question.

Test drive after connecting the battery:

The fault memories of all vehicle control modules should be read out again after the test drive.

24 70 DME control module:

After disconnection of the power supply, the idle speed might change or fluctuate briefly until the idle speed positioner (M 5.2) or the throttle adjusting unit (ME 7.2) is readapted. The mixture adaptation is also lost.

Remedy:

After the battery is connected:

With the DME ME 7.2, it is necessary to carry out a learning and adaptation routine as described below:

Switch the ignition on for 1 minute without starting the engine. Do not actuate accelerator pedal.

Switch off ignition for at least 10 seconds.

This completes the adaptation of the throttle adjusting unit.

With all DME systems, the engine must run for several minutes before the engine control module can relearn the idle speed and mixture adaptation values.

37 30 Tiptronic:

The stored pressure adaptation valves are lost if the power supply to terminal 30 is interrupted. This can result in poor shifting quality and rough shift operations during the adaptation phase.

Remedy:

Perform a test drive. During the test drive, drive the vehicle with varying load conditions and at various speeds so that all shift functions (manual and automatic programs) are executed at least once. This readapts the shifting pressures of the system and thereby re-establishes smooth shifting.

64 52 Power windows:

The limit positions of the power windows are deleted from the control module when the battery is disconnected and connected.

Remedy:

Manually close each power window as far as it will go, then press the rocker switch for closing the window again. The limit position of the respective window is now stored in the control module again.

90 25 Instrument cluster:

The trip counter is set to 0 when the power supply is disconnected.

90 30 Clock:

Depending on the software version, the clock is set to 12:00 a.m. or 1:00 a.m. when the power supply is disconnected.

Remedy:

Enter the current time again.

Note:

On vehicles with PCM, 91 10 PCM position 3.

90 80 On-board computer:

Disconnection of the vehicle battery deletes the memories for average speed and average consumption.

As a result, the displayed range on remaining fuel can be markedly different or even 0.

The outside temperature indicator loses its memory effect. In other words, the indicated outside temperature can be too high due to the heat radiated when the vehicle is hot.

91 20 Radio:

The radio reverts to the *Code* function when the battery is disconnected and is thus no longer ready for operation.

Remedy:

Input the radio code. If the code card is unavailable, the radio code can be read from the DME control module (under "Vehicle data"). The code is also available from the Porsche IPAS.

91 10 PCM:

1. The PCM reverts to the *Code input* function when the battery is disconnected and is thus no longer ready for operation.
2. When the power supply is disconnected, the built-in GPS receiver loses the so-called "*almanac*" containing the satellite orbital paths.
3. The date and time are deleted when the battery is disconnected.
4. Radio stations stored by the customer are no longer displayed.

5. If the telephone card was inserted and the telephone was ready for operation, the telephone is subsequently disabled.

Remedy:

1. Input the PCM code. If the code card is unavailable, the PCM code can also be read from the DME control module (under "Vehicle data"). This code is also available from the Porsche IPAS.
2. Switch on the PCM with a free panoramic view for approx. 20 minutes (to load GPS almanac).
3. The date and time are also adopted once the GPS almanac has been loaded (see step 2); it may be necessary to change over to summer time (daylight-saving time). This time is transferred to the instrument cluster. If the time is then manually changed by means of the instrument cluster, this time is adopted by the PCM and synchronised with GPS time.
4. The stored stations are displayed again when station buttons 1 to 6 are pressed.
5. The telephone is enabled again when the telephone PIN code is entered with the SIM telephone card inserted.

0 Technical data Boxster (2.7 l)**Engine**

Engine type:		M 96/22
No. of cylinders		6
Bore	mm	85.5
Stroke	mm	78
Cubic capacity	cm ³	2687
Compression ratio		11.0
Max. engine power as per 80/1269/EWG	kW	162
as per SAE J 1349	HP	220
at engine speed	rpm	6400
Max. torque as per 80/1269/EWG	Nm (ftlb.)	260 (192)
at engine speed	rpm	4750
Max. litre output as per 80/1269/EWG	kW/l, HP/l	60.29 (82.03)
Idle speed - manual transmission	rpm	700
Tiptronic selector lever at P or N	rpm	700
Tiptronic selector lever in driving position	rpm	700
and air conditioning on	rpm	700
Rpm limitation at	rpm	7200
Engine weight		
Manual transmission	kg	188
Tiptronic transmission	kg	178.1

Valve control		DOHC with camshaft adjustment (VarioCam)
Valve arrangement per combustion chamber		2 inlet, 2 exhaust suspended in parallel V arrangement
Valve clearance		Hydraulic valve clearance compensation
Timing with 1 mm valve travel		Inlet opens 14° after TDC Inlet closes 44° after BDC Outlet opens 141° after TDC Outlet closes 8° before TDC
 Engine cooling		
Type		Liquid cooling, two electric fans, controlled in two stages
 Motor lubrication		
		Integrated dry sump
Oil cooling		Via oil-water heat exchanger
Oil pressure at 5000 rpm		
Oil temperature 90 °C	bar	Approx. 5
Oil consumption	l/1000 km	Up to 1.0
 Fuel system		
		ME 7.2 with sequential fuel injection
Fuel supply		1 electr. fuel pump
System pressure without vacuum	bar	3.6 4.0
Fuel RON/MON		min. 98/88

**Fuel consumption
as per 93/116/EG**

		Manual transmission	Tiptronic
City	l/100 km	14.3	15.9
Highway	l/100 km	7.4	8.0
Overall	l/100 km	9.9	10.9
Target CO ₂ value	g/km	245	271

Emission control

Euro II	Oxygen-sensing closed-loop control, 3-way catalytic converter with one catalytic converter to the left and right in each case
EURO II D4	Additional secondary air system
USA LEV	Oxygen-sensing closed-loop control, 3-way catalytic converters with a start and main catalytic converter to the left and right in each case (USA) On-Board Diagnosis (OBD II) On-Board Refuelling (ORVR)

Electrical system

Nominal voltage	V	12
Alternator output	W/A	1680/120
Battery manual transmission	Ah/A	60/280
Battery Tiptronic	Ah/A	70/340
Ignition		ME 7, with static high-voltage distribution and cylinder-selective knock regulation
Firing order		1 - 6 - 2 - 4 - 3 - 5
Spark plugs		
Bosch		FGR 6 KQC
Beru		14 FGR 6 KQU
Electrode gap	mm	1.6 + 0.05

Transmission

Clutch Single-plate dry clutch with thrust plate
in pressed version, two-mass flywheel

Thrust plate GGG 60
Drive plate rigid 240

Manual transmission

Transmission ratios G 86/01

1st gear 3.50
2nd gear 2.12
3rd gear 1.43
4th gear 1.09
5th gear 0.84
Reverse gear 3.44

Final drive 3.56

Transmission weight filled with oil kg 48.3

Tiptronic A 86/01

Torque converter ø mm 254
Stall speed 1/min 2400 - 400

Transmission ratios:

1. Gear 3.66
2nd gear 2.00
3rd gear 1.41
4th gear 1.00
5th gear 0.74
Reverse gear 4.10
Final drive 4.02
(intermediate gearbox 1.21/axle 3.33)

Transmission weight filled with oil kg 101.4

Running gear**Front axle**

Spring wire \varnothing (sport-type running gear)	mm	12.6 ... 12.76 (13.30)
Coil \varnothing (sport-type running gear)	mm	148.5 (148.5)
Turns		4.55 ... 4.40 (4.40)
Tube-type stabilizer \varnothing (sport-type running gear)	mm	18.5 x 2.5 (19.6 x 2.6)

Steering

Steering wheel \varnothing	mm	380
Steering ratio (right-hand drive vehicles)		1 16.9
Lock-to-lock turns (right-hand drive vehicles)		2.98
Turning circle \varnothing	m	10.9

Rear axle

		Manual transmission	Tiptronic
Spring wire \varnothing (sport-type running gear)	mm	12.6 (13.30)	12.67
Coil \varnothing (sport-type running gear)	mm	148.5 (148.5)	148.5
Turns		4.55 (4.40)	4.75
Tube-type stabilizer \varnothing (sport-type running gear)	mm	18.5 x 2.5 (19.6 x 2.6)	18.5 x 2.5

Wheel alignment front axle

	RoW	USA
Toe-in (total)	+ 5' ± 5'	+ 5' ± 5'
Camber standard	- 10' ± 30'	+ 5' ± 30'
Camber sport-type running gear	- 15' ± 30' max. difference l. to r. 20'	
Caster	8° ± 30' max. difference to r. 40'	8° ± 30'
Toe difference angle at 20° steering angle	- 1° 50' ± 10'	- 1° 20' ± 30'
Sport-type running gear	- 2° 20' ± 30'	- 1° 20' ± 30'

Wheel alignment rear axle

Toe-in (per wheel)	+ 5' ± 5'	+ 5' ± 5'
Camber standard	- 1° 20' ± 30'	- 1° 20' ± 30'
Camber sport-type running gear	- 1° 30' ± 30'	- 1° 20' ± 30'

Brake system

Operating brake Hydraulic 2-circuit brake system, distributed per axle. Vacuum brake booster, ventilated brake discs at front and rear axle. ABS standard, Traction Control via M-number.

Brake booster	Transmission ratio	3.85
Brake master cylinder ø		
Front	mm	23.81
Rear	mm	23.81
Pressure regulator		
Activation pressure	bar	25
Reduction factor		0.46

Piston \varnothing in brake calliper		
Front	mm	36 and 40
Rear	mm	28 and 30
Brake discs \varnothing		
Front	mm	298
Rear	mm	292
Effective brake disc \varnothing		
Front	mm	250
Rear	mm	240.6
Brake disc thickness		
Front	mm	24
Rear	mm	20
Effective total pad area	cm ²	412
Parking brake		Acts mechanically on both rear wheels with deflection
Brake drum \varnothing	mm	164
Brake shoe width	mm	20
Brake pad area per wheel	cm ²	60

Wheels and tyres

Tyre size, front - on wheel	205/55 ZR 16 - 6 J x 16 H2 ET 50
Tyre size, rear - on wheel	225/50 ZR 16 - 7 J x 16 H2 ET 40
or	
Tyre size, front - on wheel	205/50 ZR 17 - 7 J x 17 H2 ET 55
Tyre size, rear - on wheel	255/40 ZR 17 - 8.5 J x 17 H2 ET 50
or	
Tyre size, front - on wheel	225/40 ZR 18 - 7.5 J x 18 H2 ET 50
Tyre size, rear - on wheel	265/35 ZR 18 - 9 J x 18 H2 ET 52
Winter tyres	
Tyre size, front - on wheel	205/55 R 16 89T M+S - 6 J x 16 H2 ET 50
Tyre size, rear - on wheel	225/50 R 16 92T M+S - 7 J x 16 H2 ET 40
or	
Tyre size, front - on wheel	205/50 R 17 89T M+S - 7 J x 17 H2 ET 55
Tyre size, rear - on wheel	255/40 R 17 90T M+S - 8.5 J x 17 H2 ET 50

or

Tyre size, front - on wheel 205/50 R 17 89T M+S - 7 J x 17 H2 ET 55
 Tyre size, rear - on wheel 255/40 R 17 94T M+S - 8.5 J x 17 H2 ET 50

Spare wheel High-pressure tyre T105/95 R 17

Tyre pressure

Front	bar	2.0 (29 psi)
Rear	bar	2.5 (36 psi)
Spare wheel	bar	4.2 (60 psi)

Dimensions and weights

			RoW	USA
Length	mm		4315	4340
Width	mm		1780	
Height	mm		1290	
Wheel base	mm		2415	
Toe width, front	16 inch	mm	1465	
	17 inch	mm	1455	
	18 inch	mm	1465	
Toe width, rear	16 inch	mm	1528	
	17 inch	mm	1508	
	18 inch	mm	1504	
Ground clearance with permissible total weight	mm		95	105
Ramp angle			12°	13
Overhang angle, front			12°	13
	rear		16.5°	16.5°

Empty weight as per DIN 700 20		Manual transmission	Tiptronic
Front	kg	585	585
Rear	kg	675	725
Total	kg	1260 – 1340	1310 – 1390
Permissible axle load			
Front	kg	775	775
Rear	kg	895	895
Permissible total weight	kg	1570	1620
Roof load with original Porsche			
Roof Transport System	kg	75	75

Filling capacities

Engine oil quantity		Oil change with oil filter approx. 8.75 Oil change without oil filter approx. 8.5
Manual transmission with final drive		2.25 (SAE 75 W 90 Burmah - Oil TAF 21)
Tiptronic oil quantity Automatic section		9.5 (ATF ESSO LT 71141)
Oil quantity, final drive		0.8 (GL5 SAE 90 or GL5 SAE 75 W 90 or Burmah SAF - AG 4/1016)
Fuel tank		65, including approx. 10 litres reserve
Brake fluid reservoir		0.39 (brake fluid Super DOT 4)
Fluid tank for power steering		1.0 (Pentosin CHF 11 S)
Windshield/headlight washer tank		2.5 7.0
Refrigerant R 134a	g	850
Refrigerant oil	cm ³	195 ± 15

Driving performance

Top speed		Manual transmission	Tiptronic
	km/h / mph	250/155	245/152

Acceleration

0 - 100 km/h	s	6.6	7.4
0 - 160 km/h	s	15.9	17.4
0 - 100 mph	s	15.9	17.4
0 - 60 mph	s	6.5	7.2
Kilometre from standing start	s	26.8	27.8
1/4 mile from standing start	s	14.8	15.3

Elasticity

80 - 120 km/h 4th gear	s	7.0	7.9
80 - 120 km/h 5th gear	s	10.4	12.3
100 - 200 km/h 5th gear	s	32.2	39.2

Specific power depending on equipment	kg/kW	8.3 ... 8.8	8.7 ... 9.1
	kg/HP	6.1 ... 6.5	6.3 ... 6.7

0 Technical data Boxster S (3.2 l)**Engine**

Engine type:		M 96/21
No. of cylinders		6
Bore	mm	93
Stroke	mm	78
Cubic capacity	cm ³	3179
Compression ratio		11.0 1
Max. engine power		
as per 80/1269/EWG	kW	185
as per SAE J 1349	HP	252
at engine speed	rpm	6250
Max. torque		
as per 80/1269/EWG	Nm (ftlb.)	305 (192)
at engine speed	rpm	4500
Max. litre output		
as per 80/1269/EWG	kW/l, HP/l	58.19/79.17
Idle speed - manual transmission	rpm	700
Tiptronic selector lever at P or N	rpm	700
Tiptronic selector lever in driving position	rpm	700
and air conditioning on	rpm	700
Rpm limitation at	rpm	7200
Engine weight		
Manual transmission	kg	188
Tiptronic transmission	kg	178.1

Valve control	DOHC with camshaft adjustment (VarioCam)
Valve arrangement per combustion chamber	2 inlet, 2 exhaust suspended in parallel V arrangement
Valve clearance	hydraulic valve clearance compensation
Timing with 1 mm valve travel	Inlet opens 14° after TDC Inlet closes 60° after BDC Outlet opens 141° after TDC Outlet closes 6° before TDC

Engine cooling

Type	Liquid cooling, two electric fans, controlled in two stages
------	---

Motor lubrication

Integrated dry sump

Oil cooling	Via oil-water heat exchanger
-------------	------------------------------

Oil pressure at 5000 rpm		
Oil temperature 90 °C	bar	Approx. 5

Oil consumption	l/1000 km	Up to 1.0
-----------------	-----------	-----------

Fuel system

ME 7.2 with sequential fuel injection

Fuel supply	1 electr. fuel pump
-------------	---------------------

System pressure without vacuum	bar	3.6 4.0
--------------------------------	-----	---------

Fuel RON/MON	min. 98/88
--------------	------------

**Fuel consumption
as per 93/116/EG**

		Manual transmission	Tiptronic
City	l/100 km	14.3	15.9
Highway	l/100 km	7.4	8.0
Overall	l/100 km	9.9	10.9
Target CO2 value	g/km	245	271

Emission control

Euro II	Oxygen-sensing closed-loop control, 3-way catalytic converter with one catalytic converter to the left and right in each case
EURO II D4	Additional secondary air system
USA LEV	Oxygen-sensing closed-loop control, 3-way catalytic converters with a start and main catalytic converter to the left and right in each case (USA) On-Board Diagnosis (OBD II) On-Board Refuelling (ORVR)

Electrical system

Nominal voltage	V	12
Alternator output	W/A	1680/120
Battery manual transmission	Ah/A	60/280
Battery Tiptronic	Ah/A	70/340

Ignition ME 7, with static high-voltage distribution and cylinder-selective knock regulation

Firing order 1 - 6 - 2 - 4 - 3 - 5

Spark plugs

Bosch		FGR 6 KQC
Beru		14 FGR 6 KQU
Electrode gap	mm	1.6 + 0.05

Transmission

Clutch Single-plate dry clutch with thrust plate in pressed version, two-mass flywheel

Thrust plate GGG 60
Drive plate rigid 240

Manual transmission

Transmission ratios G 86/20

1st gear 3.82
2nd gear 2.20
3rd gear 1.52
4th gear 1.22
5th gear 1.02
6th gear 0.84
Reverse gear 3.55

Final drive 3.44

Transmission weight filled with oil kg 62.7

Tiptronic A 86/20

Torque converter ø mm 254
Stall speed 1/min 2400 - 400

Transmission ratios

1. Gear 3.66
2nd gear 2.00
3rd gear 1.41
4th gear 1.00
5th gear 0.74
Reverse gear 4.10
Final drive 3.73
(intermediate gearbox .21/axle 3.09)

Transmission weight filled with oil kg 101.4



Running gear**Front axle**

Spring wire \emptyset (sport-type running gear)	mm	10.25 ... 13,18 (10,84 ... 13.90)
Coil \emptyset (sport-type running gear)	mm	90.5 ... 186,5 (91.68 ... 186.5)
Turns		4.05 (4.05)
Tube-type stabilizer \emptyset (sport-type running gear)	mm	23.6 x 3.5 (24.0 x 3.8)

Steering

Steering wheel \emptyset	mm	375
Steering ratio (right-hand drive vehicles)		1 16.9
Lock-to-lock turns (right-hand drive vehicles)		2.98
Turning circle \emptyset	m	10.9

Rear axle

		Standard	Sport-type running gear RoW/USA
Spring wire \emptyset	mm	12.91	13.29/13.43
Coil \emptyset	mm	148.5	148.5
Turns		4.55	4.25/4.40
Tube-type stabilizer \emptyset	mm	18.5 x 2.5	19.0 x 2.7

Wheel alignment front axle

	RoW	USA
Toe-in (total)	+ 5' ± 5'	+ 5' ± 5'
Camber standard	- 10' ± 30'	+ 5' ± 30'
Camber sport-type running gear	- 15' ± 30' max. difference l. to r. 20'	
Caster	8° ± 30' max. difference to r. 40'	8° ± 30'
Toe difference angle at 20° steering angle	- 1° 50' ± 30'	- 1° 20' ± 30'
Sport-type running gear	- 2° 20' ± 30'	- 1° 20' ± 30'

Wheel alignment rear axle

Toe-in (per wheel)	+ 5' ± 5'	+ 5' ± 5'
Camber standard	- 1° 20' ± 30'	- 1° 20' ± 30'
Camber sport-type running gear	- 1° 30' ± 30' max. difference to r. 20'	- 1° 20' ± 30'

Brake system

Operating brake Hydraulic 2-circuit brake system, distributed per axle. Vacuum brake booster, ventilated brake discs at front and rear axle. ABS standard, Traction Control via M-number.

Brake booster	Transmission ratio	3.85 1
Brake master cylinder ø front	mm	23.81
rear	mm	23.81

Pressure regulator		
Activation pressure	bar	25
Reduction factor		0.46
Piston \varnothing in brake calliper		
Front	mm	36 and 40
Rear	mm	28 and 30
Brake discs \varnothing		
Front	mm	318
Rear	mm	299
Effective brake disc \varnothing		
Front	mm	261.8
Rear	mm	247.6
Brake disc thickness		
Front	mm	28
Rear	mm	24
Effective total pad area	cm ²	450.0
Parking brake		Acts mechanically on both rear wheels with deflection
Brake drum \varnothing	mm	180
Brake shoe width	mm	25
Brake pad area per wheel	cm ²	85

Wheels and tyres

Tyre size, front - on wheel	205/50 ZR 17 - 7 J x 17 H2 ET 55
Tyre size, rear - on wheel	255/40 ZR 17 - 8.5 J x 17 H2 ET 50
or	
Tyre size, front - on wheel	225/40 ZR 18 - 7.5 J x 18 H2 ET 50
Tyre size, rear - on wheel	265/35 ZR 18 - 9 J x 18 H2 ET 52

Winter tyres

Tyre size, front - on wheel 205/50 R 17 89H M+S - 7 J x 17 H2 ET 55
 Tyre size, rear - on wheel 255/40 R 17 90H M+S - 8.5 J x 17 H2 ET 50

or

Tyre size, front - on wheel 205/50 R 17 89H M+S - 7 J x 17 H2 ET 55
 Tyre size, rear - on wheel 255/40 R 17 94H M+S - 8.5 J x 17 H2 ET 50

Spare wheel High-pressure tyre T105/95 R 17

Tyre pressure

Front	bar	2.0 (29 psi)
Rear	bar	2.5 (36 psi)
Spare wheel	bar	4.2 (60 psi)

Dimensions and weights

			RoW	USA
Length	mm		4315	4340
Width	mm		1780	
Height	mm		1290	
Wheel base	mm		2415	
Toe width, front	17 inch	mm	1455	
	18 inch	mm	1465	
Toe width, rear	17 inch	mm	1508	
	18 inch	mm	1504	
Ground clearance with permissible total weight	mm		95	105
Ramp angle			12°	13
Overhang angle, front			12 °	13
rear			16.5°	16.5°

Empty weight as per DIN 700 20		Manual transmission	Tiptronic
Front	kg	600 ... 635	600 .. 635
Rear	kg	695 ... 740	735 .. 780
Total	kg	1295 ... 1375	1335 .. 1415
Permissible axle load			
Front	kg	775	775
Rear	kg	920	920
Permissible total weight	kg	1615	1655
Roof load with original Porsche			
Roof Transport System	kg	75	75

Filling capacities

Engine oil quantity		Oil change with oil filter approx. 8.75 Oil change without oil filter approx. 8.5
Manual transmission with final drive		2.25 (SAE 75 W 90 Burmah - Oil TAF 21)
Tiptronic oil quantity		9.5 (ATF ESSO LT 71141)
Automatic section		0.8 (GL5 SAE 90 or GL5 SAE 75 W 90 or
Oil quantity, final drive		Burmah SAF - AG 4/1016)
Fuel tank		65, including approx. 10 litres reserve
Brake fluid reservoir		0.39 (brake fluid Super DOT 4)
Fluid tank for power steering		.0 (Pentosin CHF 11 S)
Windshield/headlight washer tank		2.5 7.0
Refrigerant R 134a	g	850
Refrigerant oil	cm ³	195 ± 15

Driving performance

Top speed		Manual transmission	Tiptronic
	km/h / mph	250/155	245/152

Acceleration

0 - 100 km/h	s	6.6	7.4
0 - 160 km/h	s	15.9	17.4
0 - 100 mph	s	15.9	17.4
0 - 60 mph	s	6.5	7.2
Kilometre from standing start	s	26.8	27.8
1/4 mile from standing start	s	14.8	15.3

Elasticity

80 - 120 km/h 4th gear	s	7.0	7.9
80 - 120 km/h 5th gear	s	10.4	12.3
100 - 200 km/h 5th gear	s	32.2	39.2

Specific power depending on equipment	kg/kW	8.3 ... 8.8	8.7 ... 9.1
	kg/HP	6.1 ... 6.5	6.3 ... 6.7

Sales Check

(Working position 01 01 00 00)

Working instruction to order no.

Grid for working instruction to order no. and centre's number.

Centre's number

VIN

Grid for VIN entry.

Main inspection table with columns for 'ok' and 'n ok' and rows for various vehicle checks.

ok = in order

n ok = not in order, work necessary

01 Sales check

Removing transport arrangement

Securing arrangement

Securing points (brackets) are **not present** on the running gear or body.

Spring strut locking devices

General

Spring-strut locking devices are installed at the **front axle** in order to protect new ROW vehicles with special option M 030 (sport-type running gear) during transport (e.g. onloading and offloading from trucks).

The spring-strut locking devices are **yellow**. As the reservoir tubes of the shock absorbers are painted black, the **yellow** spring-strut locking devices are clearly visible. This substantially reduces the likelihood of their being overlooked and therefore not removed.

It is not necessary to return the removed spring-strut locking device to Porsche.

Dismantling spring strut locking devices

1. Raise vehicle (wheels must be free).
The wheels need **not** be removed.
2. Remove spring strut locking devices from all spring struts. To do this, pull spring strut locking devices from the springs.

Convertible top: checking operation

Important notes

Brief operating instructions are on the reverse of the driver's sun visor.

When opening or closing the convertible top, make sure that no one can be injured by the convertible-top mechanism or the convertible-top compartment cover.

If the main carrier of the roof transport system is fitted, the convertible top must not be operated.

Items of luggage or objects on the luggage tray above the engine cover must be put in the luggage pocket or be secured under the net to prevent their being shaken out.

These objects must not affect movement of the convertible top or be in abrasive contact with the convertible top or rear window.

Do not open the convertible top at temperatures below 0°C: the rear window could break.

The convertible top must not be operated when one side of the car is on a kerb, a hoist or a jack.

The convertible top must be operated only when the car is stationary. Ensure there is sufficient room above the convertible top.

To prevent damp stains and abrasions, only open the convertible top in a dry, clean state.

If the rear window is dirty or dusty, wash it with

clean water before opening the convertible top in order to prevent scratching.

This applies in particular when the hardtop is then fitted.

If the door windows are closed, they will automatically be opened a few millimetres before the convertible top is opened or closed.

The windows must be closed with the rocker switch.

Opening convertible top

1. Unlatch the locking lever:
Press the unlocking plate (arrow A).
2. Unlocking convertible top:
Swing locking lever to rear (arrow B).

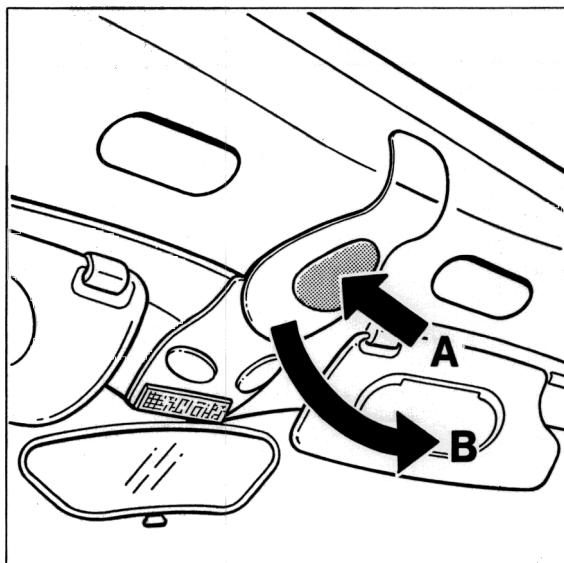

469-96

3. Opening convertible top:

Operate rocker switch uninterruptedly until indicator light in the instrument panel goes out (convertible top in final position).

If there is a hazard, release the button: convertible top operation is immediately interrupted.

Note

The convertible top can only be operated when the handbrake is applied and ignition is on (engine running or stationary).

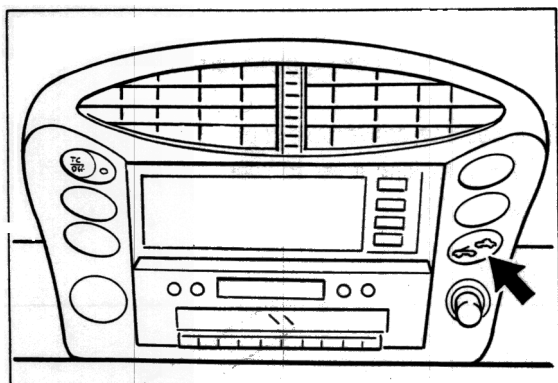

468-96

Closing convertible top

1. Closing convertible top:

Operate rocker switch uninterruptedly until indicator light in the instrument panel goes out (convertible top in final position).

If there is a hazard, release the button: convertible top operation is immediately interrupted.

2. Locking convertible top:

Swing locking lever forward (arrow B) until it perceptibly engages.

The latching hook must engage in the windscreen frame (arrow C).

The engagement of the latching hook can be assisted by pulling the convertible top by a handle in the convertible-top frame to the windscreen (arrow D).

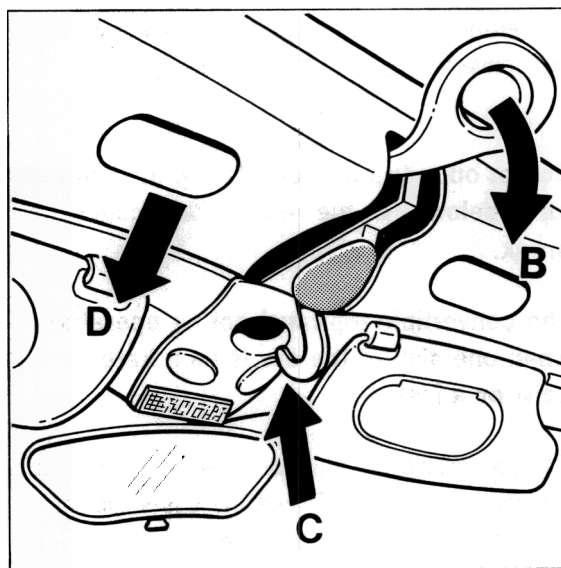

470-96

Coding alarm system for Great Britain and Belgium

1. Connect and switch on the Porsche System Tester 2.
2. Switch on ignition.
3. Select vehicle type "Boxster".
4. Select "Alarm system".
5. Select menu item "Country coding".
6. Select UK for vehicles in Great Britain or B for vehicles in Belgium.
7. Press the F 8 key.

The alarm control module has now been coded for the country in question.

Minor maintenance after 20,000, 60,000, 100,000, 140,000 km etc.	Page
Diagnosis system: Read out fault memory	1
Change engine oil	
Replace spark plugs (only on vehicles without catalytic converter)	
Vehicle underside and engine compartment: Visual inspection for leaks (oils and fluids) and chafing damage (lines and hoses)	
Power-assisted steering: Check fluid level	3
Coolant hoses: Check condition; radiators: Visual inspection for external contamination Coolant: Check the level and antifreeze protection	
Particle filter: Replace filter element	4
Brake hoses and lines: Visual inspection for damage, routing and corrosion, check brake fluid level	
Drive shafts: Visual inspection of the boots for leaks and damage	5
Tires and spare wheel: Check the condition and tire pressure	
Check the door, lid locks and safety hooks of the front lid to ensure that they are secure and functioning	
Vehicle lighting: Check function; all headlights: Check adjustment Horn: Check function	6
Windshield washer system, headlight washer: Check the fluid level and the nozzle settings, pay attention to antifreeze protection in the winter	9
All other electrical equipment and warning and indicator lights: Check function	10
Test drive: Foot and parking brakes (also actuation travel), engine, clutch, transmission, automatic speed control, steering, heating, air-conditioning system and instruments: Check function	
Oils, fluids: Visual inspection for leaks	10
Major maintenance after 40,000, 80,000, 120,000, 160,000 km etc.	
Diagnosis system: Read out fault memory	
Polyrib belt: Check condition	10
Change engine oil and oil filter	
Replace spark plugs	
Vehicle underside and engine compartment: Visual inspection for leaks (oils and fluids) and chafing damage (lines and hoses)	
Coolant hoses: Check condition; radiators: visual inspection for external contamination Coolant: Check level and antifreeze protection	
Air filter: Replace filter element	23
Particle filter: Replace filter element	
Fuel system: Visual inspection for damage, routing and secure fit of the line connections	
Power-assisted steering: Check fluid level	

	Page
Parking brake: Check free play of the parking brake lever	13
Brake system: Visual inspection of the brake pads and brake discs for wear	
Brake hoses and lines: Visual inspection for damage, routing and corrosion, check brake fluid level,	
Clutch: Check the play and pedal end position	16
Throttle actuation: Check smooth operation, check full throttle position with the tester	
Steering gear: Visual inspection of the bellows for damage	
Tie rod ends: Check play and dust bellows	
Axle joints: Check play, visual inspection of the dust bellows for damage, check the screw connections of the running gear adjustment facility, front and rear, for secure fit	17
Drive shafts: Visual inspection of the boots for leaks and damage	
Exhaust system: Visual inspection for leaks and damage, check the suspension	
Tires and spare wheel: Check condition and tire pressure	
Check the door, lid locks and safety hooks of the front lid for secure seating and function	
Seat belts: Check function and condition	18
Vehicle lighting: Check function; all headlights: Check adjustment	
Signal horn: Check function	
Windshield washer, headlight washer: Check fluid level and the nozzle settings, pay attention to antifreeze protection in the winter months	
All other electrical equipment and also warning and indicator lights: Check function	
Test drive:	
Foot and parking brakes (also actuation travel), engine, clutch, transmission, automatic speed control, steering, heating, air-conditioning system and instruments: Check function	
Oils, fluids: Visual inspection for leaks	
Additional maintenance every 80,000 km	
Replace fuel filter	23
Replace Polyrib belt	10
Additional maintenance every 160,000 km	
Manual transmission: Change oil	19
Automatic transmission: Change ATF and ATF filter	20
Automatic transmission: Change oil in the final drive	20
Yearly maintenance	
File Status Report for Long-life guarantee, for the first time after 2 years, within the framework of regular servicing	

Maintenance every 2 years Page

Change brake fluid (use only original Porsche brake fluid)	18
--	----

Maintenance after 4, 8, 10 then every 2 years

Inspect airbag system	27
Ancillary unit mounts and running gear: Visual inspection of all rubber mounts for damage	

Annual maintenance

Diagnosis system: Read out fault memory	
Vehicle underside and engine compartment: Visual inspection for leaks (oils and fluids) and chafing damage (lines and hoses)	
Power-assisted steering: Check fluid level Engine: Check oil level	
Brake hoses and lines: Visual inspection for damage, routing and corrosion, check brake fluid level	
Steering gear: Visual inspection of bellows for damage Tie rod ends: Check play and dust bellows	
Axle joints: Check play, visual inspection of the dust bellows for damage	
Drive shafts: Visual inspection of the boots for leaks and damage	
Tyres and spare wheel: Check condition and tyre pressure	
Vehicle lighting: Check function; all headlights: Check adjustment Horn: Check function	
All other electrical equipment as well as warning and indicator lights: Check function	
Test drive: Foot brake and parking brake (also actuation travel), engine, clutch, transmission, automatic speed control, steering, heating, air-conditioning system and instruments: Check function	
Oils, fluids: Visual inspection for leaks	

03 20 00 Maintenance**Diagnosis system****Reading out the fault memory**

The method of reading out the fault memory is described in the operating instructions for the Porsche System Tester 2. The operating instructions are supplied with each tester.

The Porsche System Tester 2 is connected to the vehicle via a 16-pole diagnosis socket. The diagnosis socket is located inside the vehicle near the driver (left-hand drive vehicles) or the passenger (right-hand drive vehicles) below the instrument panel.

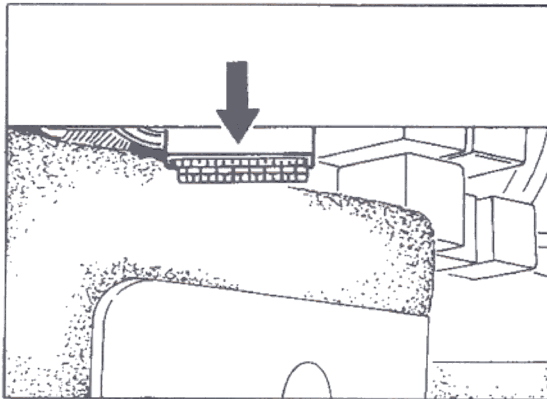

12_96

Changing the engine oil (without filter)**Requirements**

Engine at operating temperature
(70 ... 90° C oil temperature)

1. Undo the oil drain plug on the oil pan and drain off the engine oil.

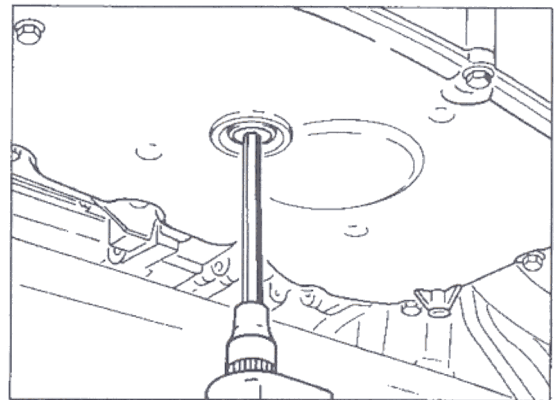

271_96

2. Clean the oil drain plug. Always replace the sealing ring.
Tightening torque 50 Nm (37 ftlb.)
3. Fill in engine oil.

The oil change quantity (without filter change) is approx. 7.75 litre.

Note

Before filling with engine oil, affix the luggage compartment protective cover recommended in the Workshop Equipment Manual.

Replacing the spark plugs

1. Lift the vehicle.
2. Undo the hexagon-head bolts on the plug coils.

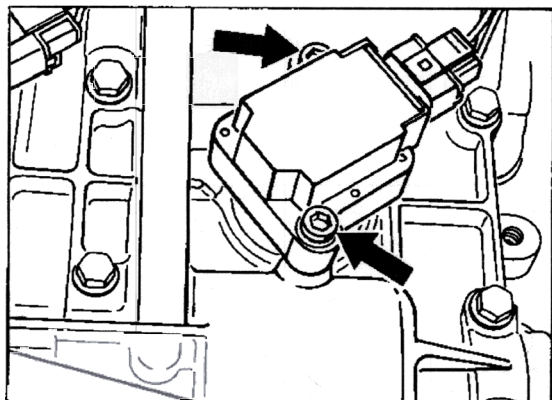

272_96

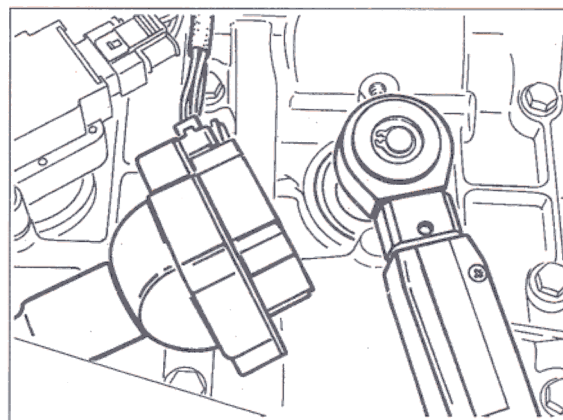

273_96

3. Pull off the plug coils and detach them to the side with connected cable.
4. Unscrew or tighten the spark plugs with the standard socket key insert from the Snap - On company, Order No. S 9706, and the Snap - On extension, Order No. FXW 4.

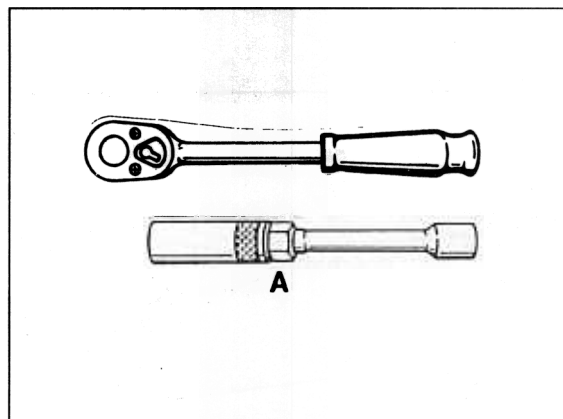

A – Snap - On tools

637_96

Note

Only this spark plug wrench from the Snap - On company was tested and approved.

Tightening torque: 30 + 3 Nm (22 + 2.0 ftlb.)

Underside of vehicle and engine compartment

Visual inspection for leaks (oils and fluids) and abrasion (lines and hoses)

Power-assisted steering

Checking the fluid level

General

Damage to the power-assisted steering is caused by a shortage of oil in the hydraulic system. Even small leaks can cause the fluid to escape and damage the servo pump as a result of the high oil pressure occurring in the hydraulic circuit.

Grunt-like noises when the steering is locked or foam formation in the reservoir indicates a shortage of oil and/or that air has also been sucked in. However, before topping up the reservoir, remedy any leaks on the suction side and replace the faulty part on the pressure side.

Checking the fluid level for the power-assisted steering

The reservoir is located in the engine compartment. There are two markings on the dipstick located on the reservoir cap. Here, the marking "Cold" for the cold engine (approx. 20 °C) is on one side and the marking for the hot engine "Hot" (approx. 80 °C) is on the other side.

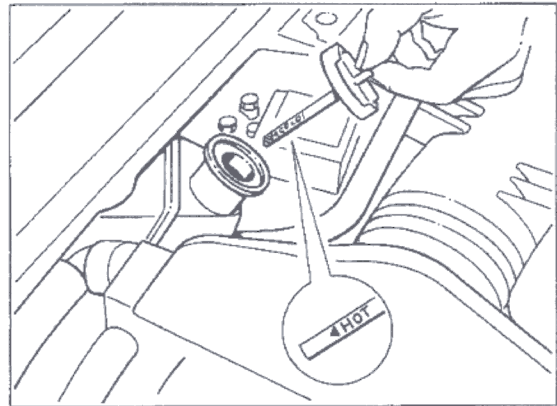

13296

Check the fluid level (Pentosin CHF 11 S) **when the engine is not running and when it is cold** (approx. 20 °C).*

1. Open the engine cover. Open the cap of the reservoir.*
2. Wipe off the dipstick.
Close and then reopen the cap. The fluid level should be in the shaded area **below** the "Cold" marking (marking = max. level at 20 °C). Top up with Pentosin if necessary.*
The top marking "Hot" is intended for a fluid temperature of 80 °C.

* **When topping up or filling in Pentosin, make sure that Pentosin does not come into contact with the coolant hoses!** Observe the specifications in order to avoid overfilling and therefore overflowing.
If coolant hoses come into contact with Pentosin, thoroughly clean them with water IMMEDIATELY!
Replace visibly swollen coolant hoses!

Coolant hoses

Check their condition

Radiators

Visual inspection for external contamination

Note

If necessary, the cooling air inlet channels upstream of the radiators can be cleaned with a vacuum cleaner nozzle (crevice nozzle) from the Kärcher company, part number 6.900 - 922.0 (length 56 cm).

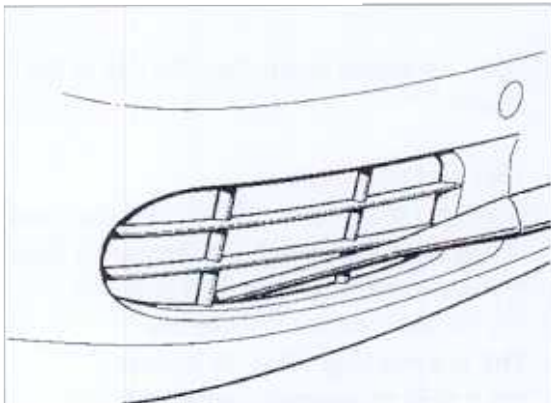

311-96

Coolant

Check the level and antifreeze protection

Note

The engine cooling system was filled with a lifetime coolant filling at the factory. This coolant must not be mixed with or replaced by other coolants. Only **Original Porsche coolant** must be used when changing or topping up the coolant.

Particle filter

Replace filter element
(with and without activated carbon)

Note

The particle filter is installed on the right in front of the heating/air-conditioning system.

Removal

1. Remove the cover for the heating and air-conditioning system.
2. Pull the particle filter upwards out of the housing guide.

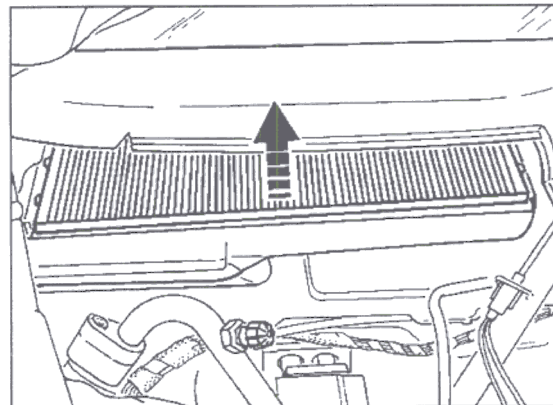

7-96

Installation

1. Insert a new particle filter into the housing guide. Check that the filter is correctly fitted and in the correct installation position.

Brake hoses and lines

Visual inspection for damage and routing (corrosion)

Check the brake fluid level

Adjust the brake fluid level if necessary (markings are on the brake fluid reservoir). Never top up above the max. marking. Use only Super DOT 4 brake fluid.

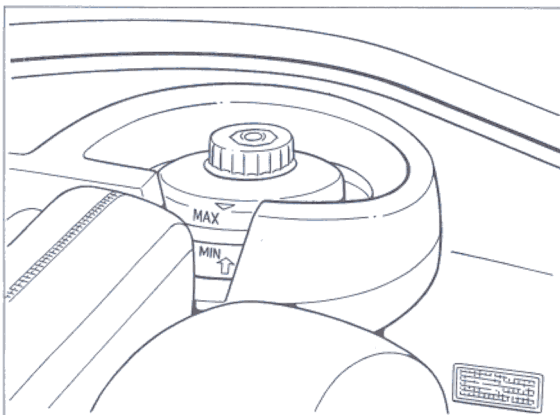

189 - 96

Drive shafts

Perform a visual inspection of the boots for leaks and damage

Tires

Check the condition and the tire pressure

Tire condition

Tires are a safety element which fulfil the demands placed on them only if they have the correct air pressure and a sufficient tread depth.

The stated air pressures are minimum pressures and must never be fallen below, since in addition to the unfavorable driving performance, this would bring about a risk of serious tire damage.

Valve caps protect the valve from dust and dirt and therefore from leaks. Always screw on the caps tightly and replace missing valve caps.

For safety reasons, in addition to checking the air pressure you should perform a visual inspection for sufficient tread depth, foreign bodies, pricks, cuts, cracks and bulges on the side wall (ply breakage).

Tire pressure of cold tires (approx. 20 °C)

16 inch and 17 inch wheels

(summer and winter tires)

front 2.0 bar overpressure

rear 2.5 bar overpressure

Emergency wheel

front/rear 4.2 bar overpressure

Oil the door hinges

Check the door locks, lid locks and safety hooks of the front lid to ensure that they are secure and functioning properly

Secure fit inspection

The fastening screws for the door lock, front lid lock and rear lid lock, as well as the retaining nuts for the upper parts of the locks of the front and rear lids must be tightened with 10 Nm (7 ftlb.).

Functional inspection

Door lock

The door lock must engage in two stages through the locking wedge when the doors are closed and must disengage again when the door handle is operated (inside and outside).

Lid lock, front and rear

The lid locks must engage by insertion of the lock upper parts when the lids (front and rear) are closed and must disengage again when the lid releases are pulled.

Safety hook, front lid

The front lid must be held down by the safety hook after the lid lock is opened. At the same time, the safety hook must engage in the retaining plate at its lowest point.

When the lid is open, the return spring must pull back the safety hook until it makes contact with the base plate of the lock upper part.

Checking the function of the vehicle's lights

Adjusting the main headlights

1. Open the luggage compartment lid.
2. Remove the luggage compartment mat on the wheel housing wall.
3. Open the cover for the headlight adjustment screws.

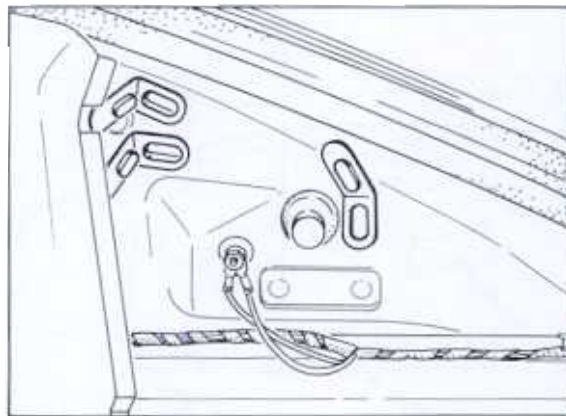

8 - 96

4. Clean the cover disk and switch on the dipped beam headlights.
5. The vehicle must be on a horizontal surface. Make the adjustment with the vehicle ready for driving (fuel tank full, driver's seat occupied by a person or by 75 kg, the tire pressure must correspond to the stipulated values) using a headlight adjustment unit.

Note

Make the adjustment with the regulator switch set to 0 (headlight beam adjustment).

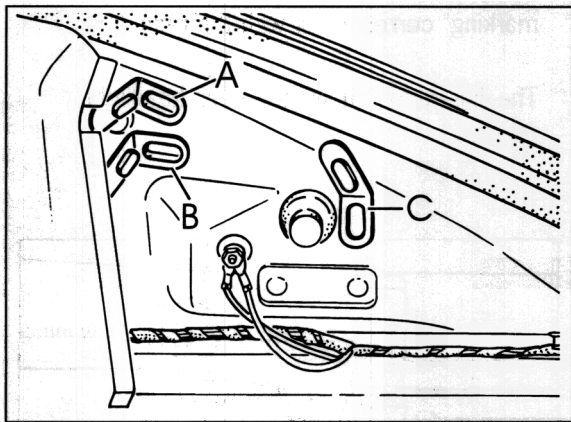

A – Lateral adjustment
B – Height and side adjustment
C – Fog light adjustment

8.1_96

Use a standard 5 mm ball-head screwdriver to make the headlight adjustment. Only the lower screw may be turned for height adjustment; for lateral adjustment the upper and lower screws must be turned in the same direction and for the same number of rotations.

Adjustment**Note**

Set the headlight adjustment unit to 10 cm/10 m (1%).

1. First, make the vertical adjustment of the dipped beam headlights. To do this, line up the light/dark borderline running upwards at an angle on the right hand side with the dotted 15° line of the adjustment unit.

2. Next, perform the horizontal adjustment of the dipped beam headlights. To do this, line up the left, horizontal part of the light/dark limit (in the case of driving on the right) with the dotted horizontal line of the adjustment unit. With this alignment, preference must be given to the central zone around the salient point of the light/dark limit.

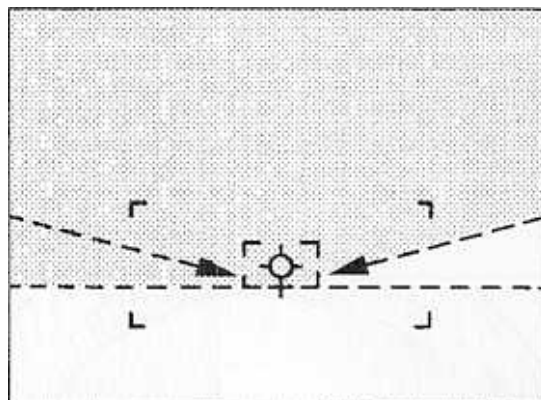

290_96

Note

The distance between the headlights and the adjustment unit should be as small as possible. It should not exceed 30 cm, because if the distance is greater, it is no longer possible to clearly define the formation of the light/dark limit in the adjustment unit.

Secure the plugs after making the adjustment. For **Litronic headlights** the ignition must be switched off and on after adjustment with the lights switched on. After this, the adjustment must be checked again.



Adjusting the main headlights - USA version

Note

In accordance with the specifications, the headlights have a spirit level (A) secured to the lens in the side area in a location clearly visible from the outside.

This is used for adjusting and checking the height adjustment.

An adjustable slider (B) is attached at the side to the lens to enable the lateral adjustment to be checked. This slider is set to the "zero adjustment marking" at the factory following the main headlight adjustment.

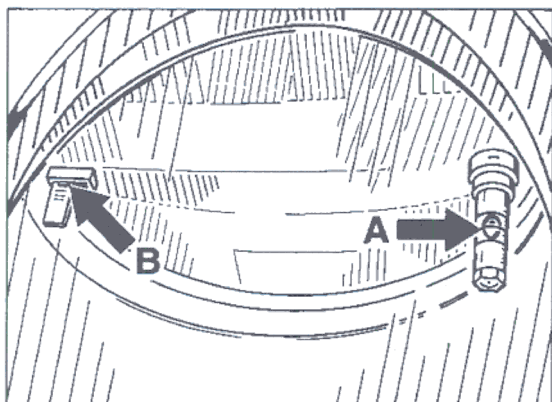

023_96

Following a correct main headlight adjustment, the spirit level must be between the marking. The lateral adjustment of the main headlights is marked by the adjustable slider. This zero adjustment marking is set at the factory and must not be readjusted.

A new adjustment may only be made in the case of **accident repairs or replacement of the main headlights.**

Setting the zero adjustment marking

1. After the main headlight adjustment, turn the adjustment screw of the slider (checking the lateral adjustment) with a 5 mm ball head screwdriver until the "zero adjustment marking" corresponds with the reflector.

The illustration shows the main headlight removed.

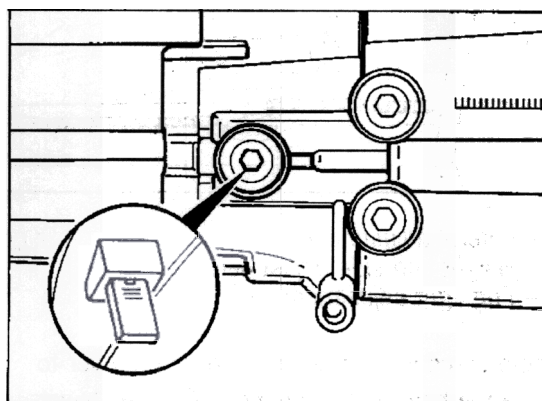

024_96

2. Adjustment screw through the luggage compartment, see Figure 11 - 96 C.

Note

Spirit level A (Fig. 023_96) has been omitted for the beginning of the '98 model of the main headlights, USA version. As a result, subsequent adjustment of the slider (Fig. 024_96) for zero adjustment marking is also omitted.

Vertical and horizontal adjustment must be carried out with a headlight adjustment unit.

Adjusting the fog lights

The vehicle must be on a horizontal surface. Make the adjustment with the vehicle ready for driving (fuel tank full, driver's seat occupied by a person or 75 kg, the tyre pressure must correspond to the stipulated values) using a headlight adjustment unit.

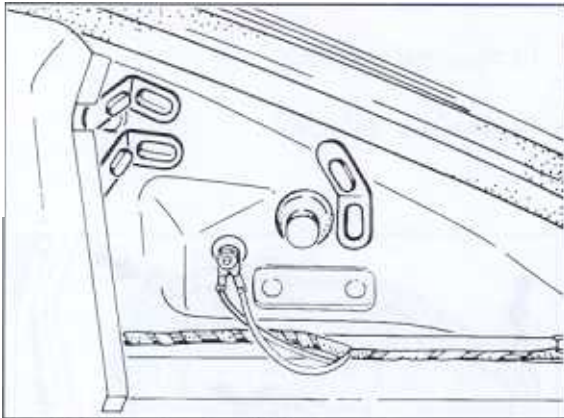

C – Adjusting the fog lights

8_96

Note

Switched-on headlights must not be covered by a front apron or film.

Removing and installing the main headlights

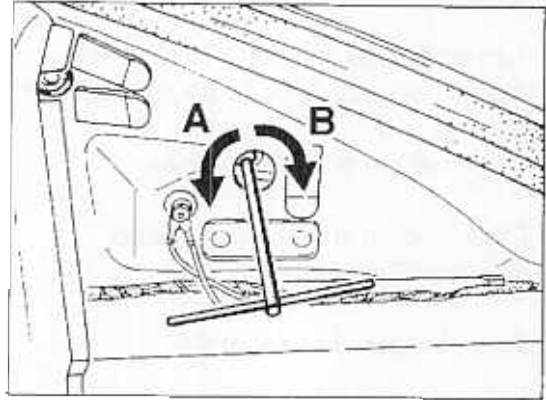

A – Open
B – Close
C – Slider adjustment (USA)
Secure the plugs after installation.

11_96

Windscreen washer system, headlight washer system

Check the function, fluid levels and nozzle settings

Note

The headlight washer nozzles are pre-set. It is not necessary to adjust them.

Use only soapy water to clean the exterior lights and the plastic headlight lenses. Never use chemical cleaning agents. To avoid scratches, do not rub with dry or only damp cloths, paper towels or insect-removal sponges.

Check the function of all other electrical equipment, as well as the indicator and warning lights:

1. Turn ignition key and check function of warning and indicator lights (visual inspection)
2. Check function of power windows
3. Check function of rear window heater (see under Serv. No. 64 86 01)
4. Check function of heater blower
5. Check function of front seats
6. Check function of radio
7. Check function of door mirror

Test drive

Check the function of the foot and hand brakes, clutch, automatic speed control, steering, heating, air-conditioning system and instruments.

Oils and fluids

Visual inspection for leaks

Drive belt

Check condition and replace if necessary

Removal

1. Remove left-hand seat. Disconnect the electrical plug connection. Undo four Torx screws with socket TX 50 (3/8 inch).
2. Remove rear wall lining.
3. Remove rear wall cover.

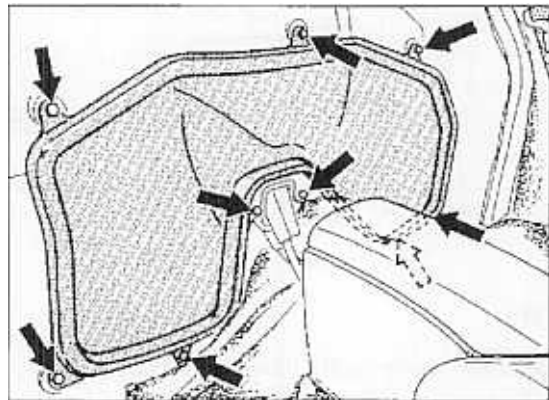

274_96

4. Mark the running direction of the belt with a colored pen. Relieve the belt tension. To do this, turn the tensioning roller (a/f 24) clockwise and simultaneously remove the belt from the drive wheels.

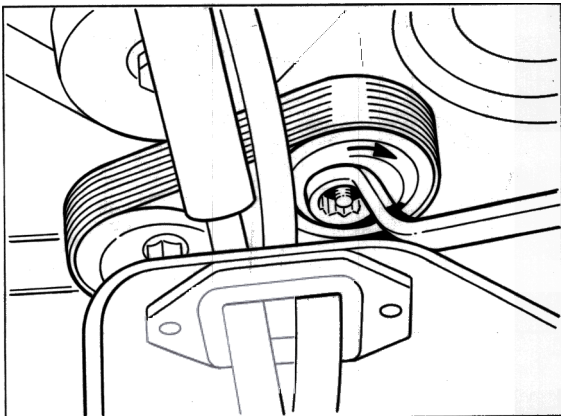

275 - 96

5. Visually inspect the condition of the belt and replace it if necessary.

Installation

1. Tensioning the toothed belt slightly by hand, fit it in the order described below:

1. Coolant-pump drive pulley (1)
2. Generator drive pulley (2)
3. Deflection roller 1 (3)
4. Power steering pump drive pulley (4)
5. Air conditioning compressor drive pulley (5)
6. Crankshaft pulley (6)
7. Tensioning roller (7)

Then turn the tensioning roller (7) in clockwise direction and simultaneously fit the drive belt on the deflection roller 2 (8).

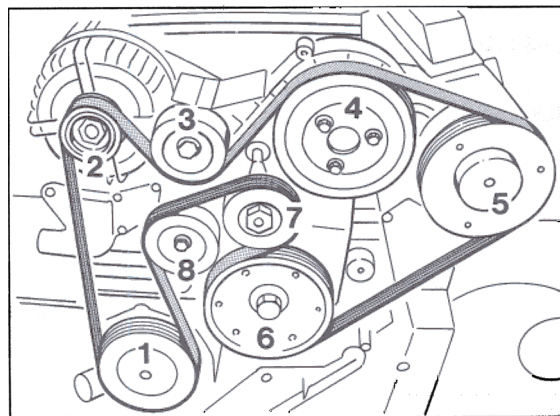

276 - 96

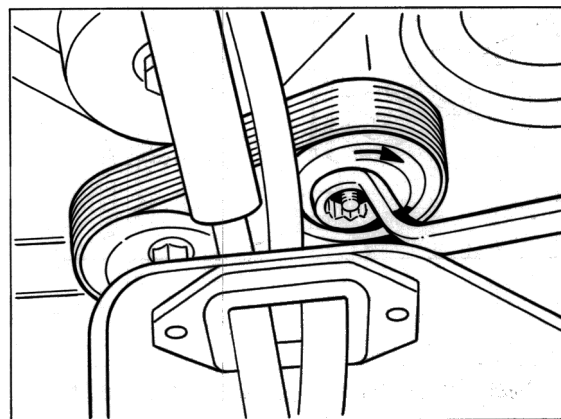

277 - 96

2. Slowly relieve the tensioning roller.
3. Visually check whether the belt is correctly positioned on all drive pulleys.
4. Fit rear wall liner, rear wall lid and seat again.

Changing the engine oil and oil filter

Requirement:

Engine at operating temperature
(70 ... 90 °C oil temperature)

1. Undo the oil drain plug on the oil sump and drain off the engine oil.

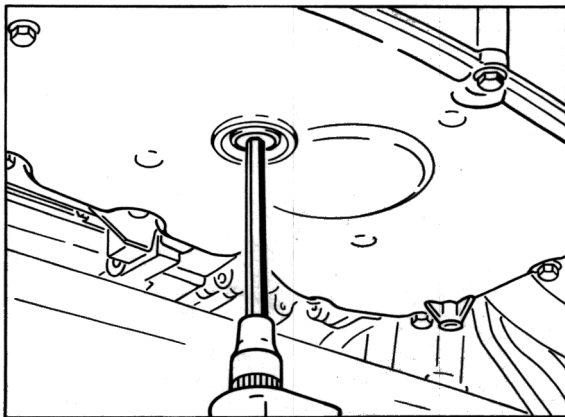

271 - 96

2. Clean the oil drain plug. Always replace the sealing ring.
Tightening torque 50 Nm (37 ftlb.).

3. Undo the oil filter with the special tool 9204.

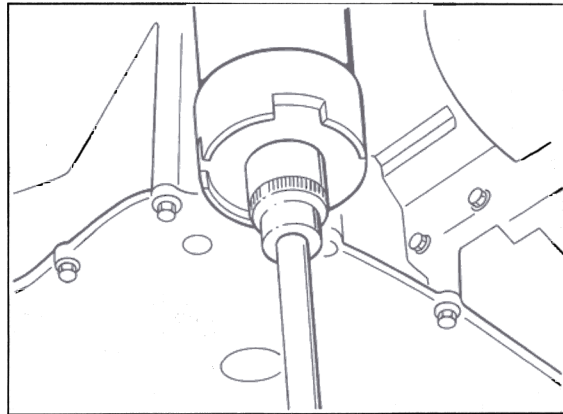

322 - 96

4. Remove the oil filter element.

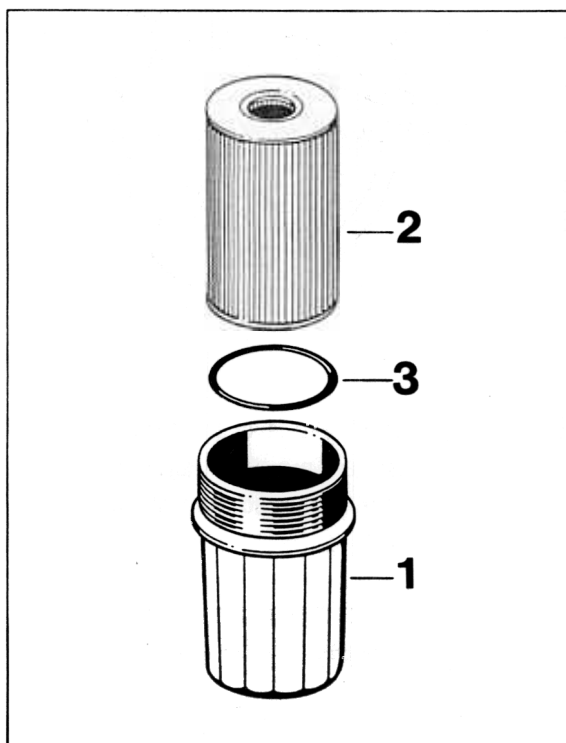

1. - Oil filter housing
2. - Filter element
3. - Sealing ring

699 - 96

Handbrake

Check the free play of the handbrake lever

The handbrake has asbestos-free brake pads. The handbrake with asbestos-free brake pads must **never be adjusted** so that the pad has to "grind free" during operation.

The handbrake must be adjusted if the handbrake lever can be pulled up by more than 4 teeth with medium force application without a braking effect being apparent.

Adjusting the handbrake:

1. Remove the rear wheels.
2. Undo the handbrake lever and push back the disc brake pads of the rear axle until the brake disc can rotate freely.

Tightening torques:

Oil drain plug on
oil pan 50 Nm (37 ftlb.)

Oil filter on
crankcase 25 ± 1 Nm (18 ± 1 ftlb.)

The oil change quantity (with filter change) is approx. 8.25 l.

3. Undo the adjustment nuts on the turnbuckle (arrow) until the cables are without pretension.

Note

To make the turnbuckle accessible, open the cover of the tray behind the handbrake lever and remove the rubber inlay and also the insert.

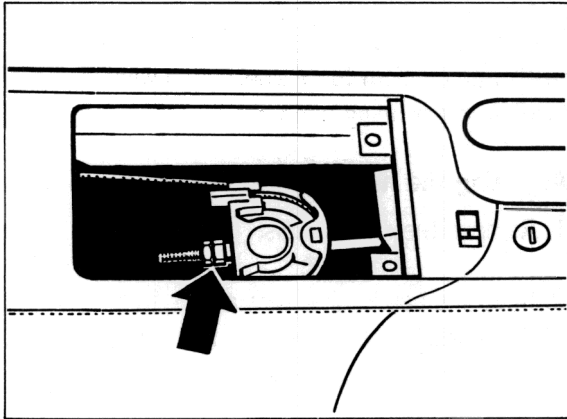

18 - 96

4. With a screwdriver, adjust the adjustment fixture through a threaded wheel bolt hole until the wheel can no longer be turned. Next, turn back the adjustment fixture through 9 notches again (release approx. 5 notches until the wheel can be turned freely, then release another 4 notches).

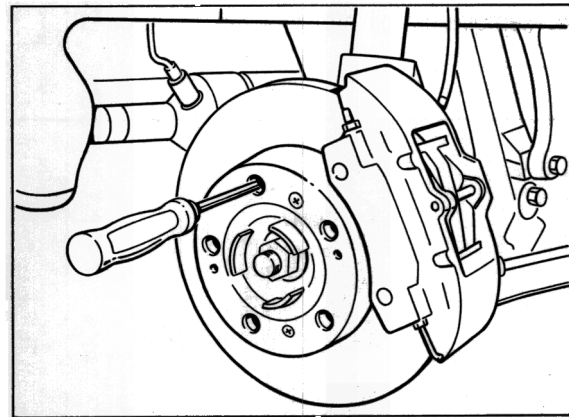

177 - 96

5. Pull up the handbrake lever by 2 teeth and turn the adjustment nut of the turnbuckle until both wheels can be turned manually with difficulty.
6. Release the handbrake lever and check whether both wheels can be turned freely.

Brake system

Visual inspection of the brake pads and brake discs for wear

Note

The brake pads must be replaced when the brake pad warning indicator lights up, but no later than when there is a residual pad thickness of 2 mm (per axle). If brake pad wear is indicated by the warning light, the warning contact (sender including wire and plug connection) must also be replaced. Replacing the warning contact or warning contacts can be avoided by replacing the brake pads no later than when the pad thickness is still 2.5 mm. Warning contacts must be replaced if the core of the wire is worn. However, if only the plastic part of the warning contact is worn, there is no need to replace it.

1. To check the brake pads, remove the wheels.
2. Visually inspect the brake pads for wear.

The wear limit is reached when the pad has a residual thickness of 2 mm.

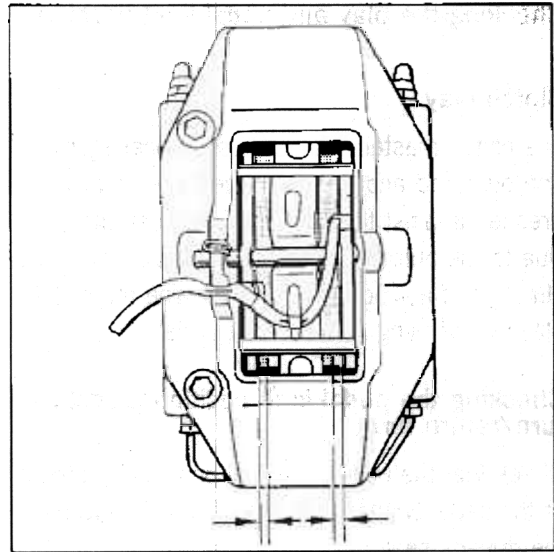

22_96

Clutch

Checking the play and pedal limit position

Clutch play

The clutch master cylinder has an inner stop. The push rod and the clutch pedal are always pressed against this stop by the boost spring. Due to the automatic hydraulic adjustment of the clutch, it is not possible to determine the clutch play by checking at the clutch pedal.

Checking the pedal limit position (pedal return/return force)

Check that the pedal is in end position by pulling at the pedal (without the use of force) towards the driver's seat.

The pedal must not give way during the process. If it gives way, the fault is in the boost spring (arrow) or in the pedals (observe the following instructions).

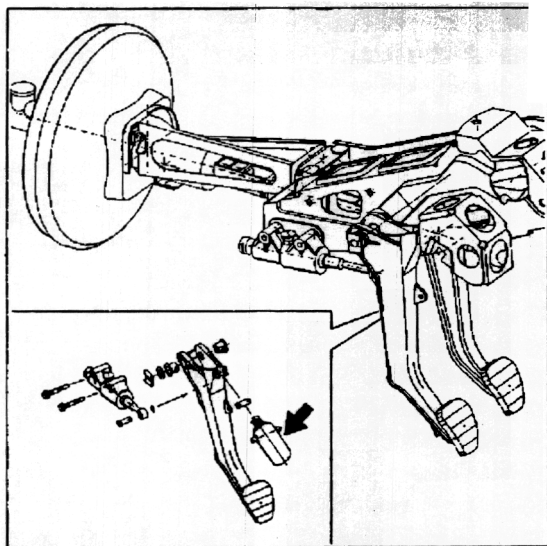

267_96

Note

The clutch push rod and the boost spring are not adjustable. The boost spring has 2 functions, namely to provide pedal force assistance and to return the pedal.

The following are some of the points which are requirements for perfect clutch operation:

Correct bleeding of the clutch hydraulics

No leaks in the hydraulic system

Pedal return to the starting position

Installation position of the pedals in accordance with the series condition

Throttle valve operation

Check smooth operation, check the full throttle position with the Tester

Steering gear

Visually inspect the bellows for damage

Track rod joints:

Check the play and dust bellows

Check the function of the dust bellows, bellows and joints and ensure that they are free of leaks.

The rubber dust bellows and bellows on the steering gear and on the tie rods can be damaged by external influences, e.g. stone impact, or during assembly work. If a rubber dust bellows leaks, the joint or the tie rod must be replaced, because dirt or moisture entering will destroy the joint.

Axle joints

Check the play and visually inspect the dust caps for damage.

Inspect the dust bellows of the axle joints (ball joints) on the suspension (front and rear) as follows:

Put the vehicle onto a lifting platform with the steering lock disengaged.

Perform a visual inspection after cleaning. When doing so, the rubber dust bellows should be pressed down with the fingers in order to reveal hidden cracks.

The procedure for the front axle is as follows: Turn the front wheels as far as they will go. Perform a visual inspection of the visible surfaces on the left and on the right.

After turning the front wheels to the other steering stop, check the other half of each rubber dust bellows.

Note

In the vicinity of the brake cover panels, no visual inspection is possible in a small area. Check this area by feeling.

If a rubber dust bellow leaks, the corresponding joint or control arm must be replaced, because dirt or moisture entering will destroy the joint.

Running gear adjustment (wheel alignment values)

Check that the screw connections of the suspension adjustment system (wheel alignment values) at the front and rear are secure.

Seat belts

Check function and condition

Functional inspection:

It must be possible to smoothly unroll the belt strap from the belt retractor via the deflector fitting by pulling evenly, and the tongue of the seat belt must engage audibly in the buckle. Jerkily pulling on the belt strap must lock the belt retractor.

Condition inspection:

The belt strap must undergo a visual inspection for damage. If it displays evidence of damage in the form of cuts, fraying, seam tears etc., the seat belt must be replaced.

Changing the brake fluid (Vacuum brake booster)

Important notes

Use only new brake fluid DOT 4. **Observe the change interval and the brake fluid quality.** Total brake fluid change quantity **approx. 1 liter.**

The brake fluid change interval is 2 years in conjunction with the Super DOT 4 brake fluid.

Procedure for changing brake fluid

- Fill up the brake fluid reservoir with new brake fluid up to its top edge. **Connect a bleeding device to the brake fluid reservoir.** Switch on the bleeding device. Bleeding pressure approx. 1.5 bar.

Continue with the brake fluid change at the brake calipers (no particular tire sequence). Open every bleeder valve until clear brake fluid free of air bubbles escapes and until the corresponding change quantity per caliper is reached (approx. 250 cm³). It must be noted that bleeding takes place at both bleeder valves on each caliper.

Use a collecting bottle to accurately check the escaping brake fluid for cleanliness, lack of air bubbles and to determine the brake fluid used.

Some brake fluid is also drained off at the bleeder valve of the clutch slave cylinder (approx. 50 cm³).

Switch off and disconnect the bleeding device. Correct the brake fluid level if necessary.

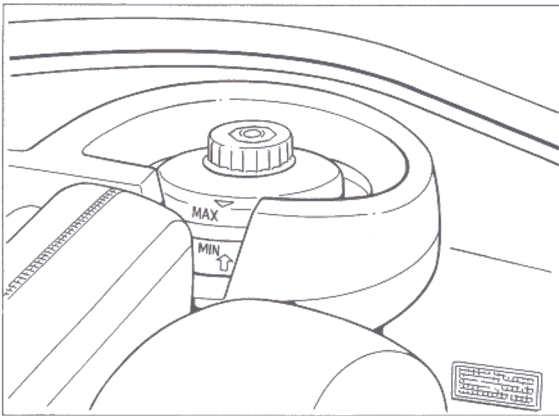

189 - 96

Note

At 2.25 l, the oil level is 11 mm below the oil filler opening.

Use an angled wire hook (shop-made) to perform the inspection.

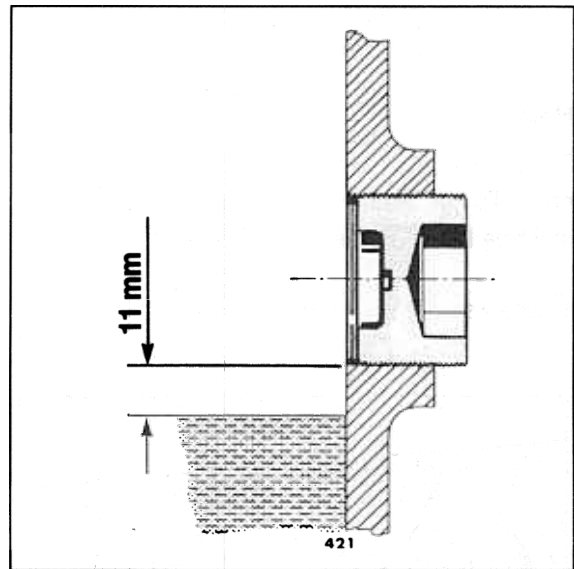

190 - 96

Replacing and checking transmission oil (manual transmission G 86/00)

Filling capacity: 2.25

Oil type:

Hypoid gear oil SAE 75 W 90 Burmah-Oil TAF 21

1. Remove the transverse strut panel.
2. Unscrew the oil drain plug with a socket key insert (e.g. Hazet 2567-16) and drain off the oil with the vehicle standing on a horizontal surface.
3. Clean the drain and filler plug.
4. Fill up with 2.25 l of transmission oil with the vehicle standing on a horizontal surface.

5. Tighten the drain and filler plug with 25 Nm (18 ftlb.).

Changing and checking the gear oil in the final drive (Tiptronic transmission A 86/00)

Filling capacity: approx. 0.8

Oil type: Hypoid gear oil
Burmah-Oil
SAF - AG 4/1016

Note

The oil drain plug is not present at the final drive. To change the oil, the final-drive cover must be removed (see Page 39 - A7).

1. Unscrew the plug (arrow).

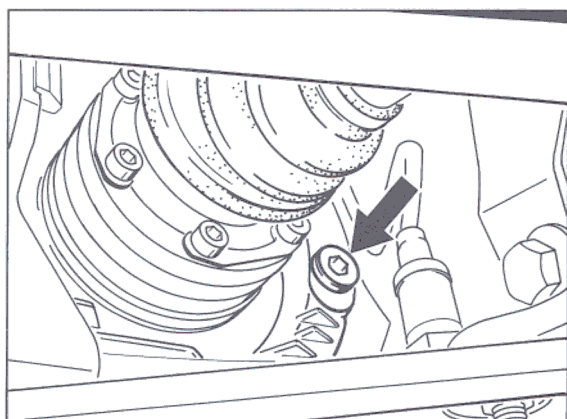

234 - 96

2. Fill up with the prescribed oil type. The fluid level must be up to the lower edge of the filler opening in this case.
3. Replace the toroidal sealing ring for the plug and tighten the screw with 30 Nm (22 ftlb.).

Checking and topping up the ATF fluid

ATF type: ESSO LT 71141

Only ATF with the designation ESSO LT 71141 may be used for topping up. No additives may be used.

Note

The stipulated fluid level (3) is extremely important to perfect functioning of the automatic transmission. It is correct if there is still a slight amount of ATF escaping at the filler screw (2) hole at temperatures between 30 °C and 40 °C.

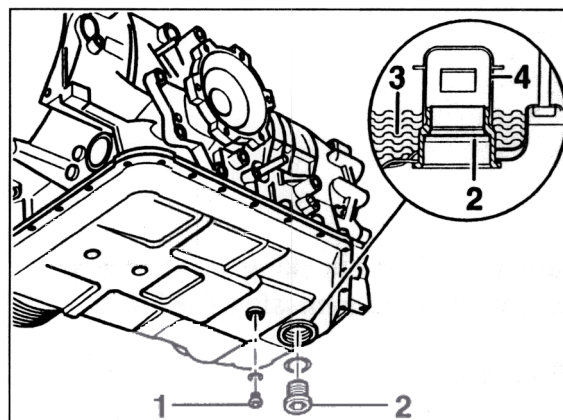

236 - 96

Testing conditions:

- The transmission must not be in the reduced driving program.

The ATF temperature must be between 30 °C and 45 °C.

An ATF inspection at an insufficient ATF temperature causes over-filling and an inspection at an excessive ATF temperature causes insufficient filling.

Selector lever in position "P" and engine running at idling speed.

The air-conditioning system and the heater must be switched off.

The vehicle must be standing horizontally.

1. Attach the filled ATF container (special tool V.A.G 1924) as high up on the vehicle as possible.
2. Place an oil collecting trough under the transmission.
3. Connect the Porsche System Tester 2 and call up the ATF temperature.

Note

The ATF temperature must not be higher than 40 °C at the start of the inspection.

4. Move the selector lever to the position "P" and allow the engine to run at idling speed.

5. **Put on protective goggles** and unscrew the ATF filler screw (2). If ATF escapes from the filler screw (2) hole and if the ATF temperature is 30 °C...40 °C, the ATF level is in order.

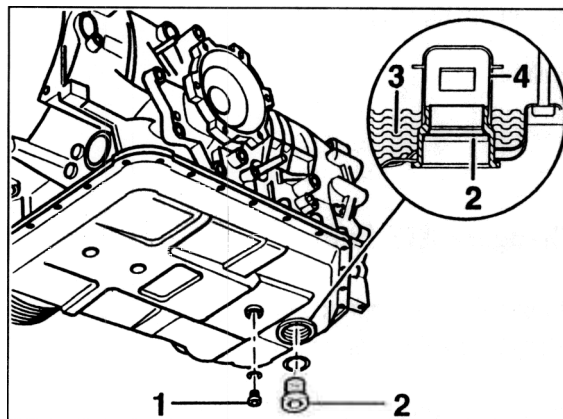

236 - 96

6. Screw in the ATF filler screw with a new sealing ring and tighten it with 80 Nm (59 ftlb.).

Note

The filler screw must be closed no later than when an ATF temperature of 45 °C is reached.

7. If no ATF escapes from the filler screw (2) even though approx. 40 °C has been reached, the ATF must be topped up.
8. Top up the ATF with the special tool V.A.G 1924 until surplus ATF runs out at the hole (2).

Note

The filler hook must be carefully inserted into one of the openings of the ATF thrower cap (4) on the filler hole. When doing so, do not move the filler hook upwards, since the oil guard cap (4) can spring off upwards.

Changing ATF fluid

Filling capacity: approx. 9 l

Change quantity: approx. 3.5

ATF type: ESSO LT 71141

Remove the transverse strut panel.

2. Position an oil collection trough under the transmission.
3. Unscrew the drain plug and drain off ATF.

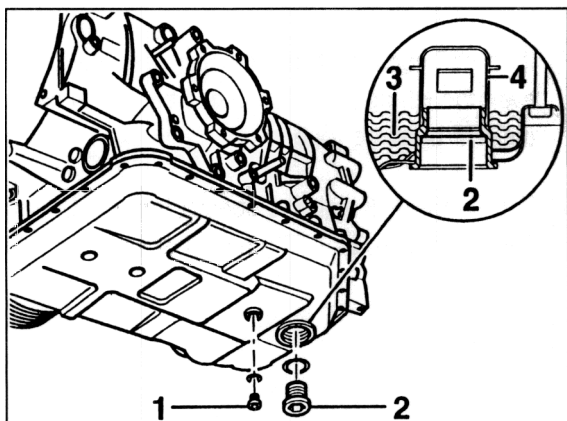

236 - 96

Note

Without ATF, the engine must not be started and the vehicle must not be towed.

4. Replace the sealing ring for the ATF drain plug (1) and tighten the screw with 40 Nm (29 ftlb.).
5. Unscrew the ATF filler screw (2) and fill up with ATF until surplus ATF escapes at the hole of the ATF filler screw.
6. Move the selector lever to the position "P" and allow the engine to run at idling speed.
7. With the engine running, again top up with ATF until surplus ATF escapes at the hole of the ATF filler screw (2).
8. With the brake pedal pressed, change through all selector lever positions, remaining in each position for approx. 10 s.
9. Check the ATF level again and top up if necessary.

Note

All instructions and inspection conditions listed under "Checking and topping up the ATF fluid" must be observed.

Air cleaner

Replacing the filter element

Removal

1. Press out spring clips and pull out drawer with filter insert.
Replace filter insert.

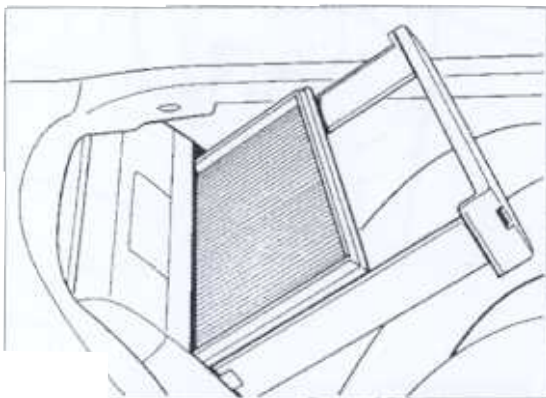

280_96

Installation

1. Position pushing unit with filter insert so that it is hanging.

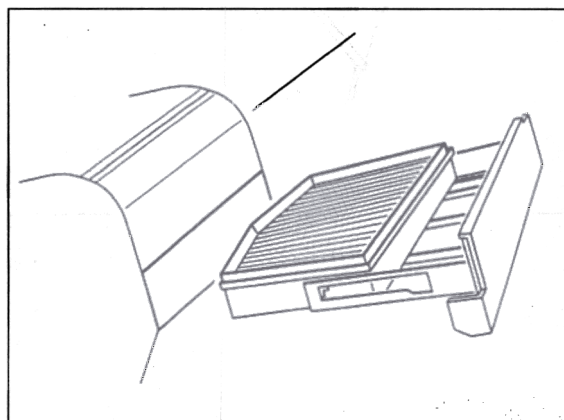

69_97

2. Clean the air cleaner housing with a vacuum cleaner. Do not carry out the cleaning work with compressed air.

Note:

The hot film mass air flow meter can be damaged if compressed air is used to clean the air cleaner housing.

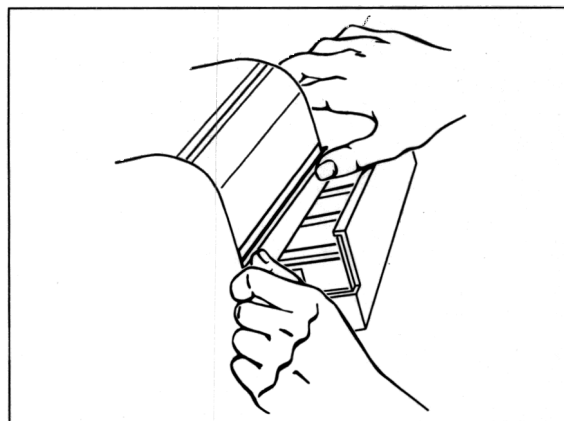

070_97

3. **Push in** pushing unit **evenly** until this can be heard to engage.

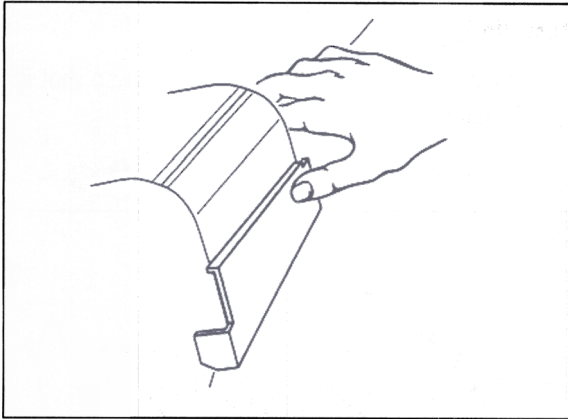

71_97

Replacing the fuel filter

1. Remove the underbody cover.
2. Pull off the ground cable from the filter.

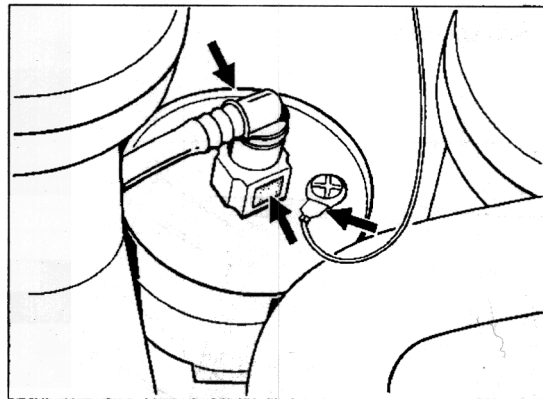

281_96

3. Disconnect the plug connection and collect the residual fuel.

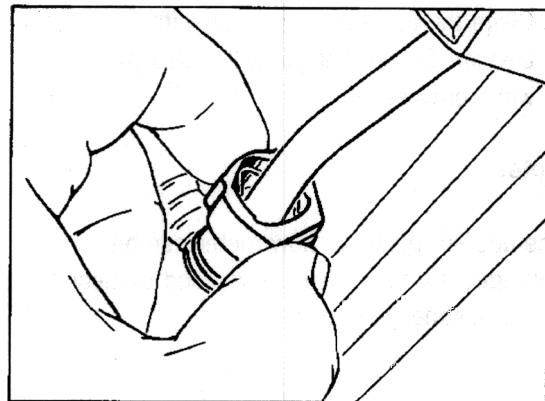

368_96

4. Undo the restraining strap and remove the fuel filter to the rear.

Note

Note

- a. Connect and disconnect the plug connection only in a straight line.
- b. **Never use excessive force.**
- c. Always take great care to protect the plug and socket piece from dirt and scratches.
- d. Check that the **connection is correctly locked** by pulling gently.

Checking operational readiness of airbag system

1. Function test of airbag warning light.
Switch on ignition to carry out this test. The airbag warning light must light up for approx. 3 seconds. If the warning light does not light up, check the bulb and power supply.
2. Function test of airbag system.

Connect and switch on the Porsche System Tester 2

Switch ignition on
 - Establish communication with the AIRBAG/POSIP control module
 - Read out fault memory: no fault present
 - Remove E1 fuse
 - Fault present after approx. 30 seconds "Airbag warning light"
 - Insert E1 fuse again
Fault no longer present after approx. 30 seconds
 - Clear the fault memory
3. Check that no linings, stickers or similar are attached to the steering wheel and in the vicinity of the passenger's airbag or side airbag.
4. Visual inspection of the components for damage and changes.
5. The system check must be acknowledged in the stamp spaces provided in the Guarantee and Maintenance booklet.